

ENGLISH



**TVS** **NEED**  
**SERIES**

**Owners Manual**

NSE 0000001

© PT TVS Motor Company Indonesia



**CONTENTS****CONTENTS****Preface**

<b>1. Specifications</b>	<b>1</b>
<b>New vehicle delivery certificate</b>	<b>6</b>
<b>Pre-delivery check</b>	<b>7</b>
<b>2. Important information</b>	<b>10</b>
<b>3. Know your NEO</b>	<b>14</b>
<b>4. Features &amp; benefits</b>	<b>36</b>
<b>5. Maintenance</b>	<b>40</b>
<b>6. Service records</b>	<b>60</b>

## PREFACE

Dear NEO Owner

Congratulations!

Welcome to the family of millions of satisfied TVS Customers across the world by choosing TVS NEO.

This manual explains about the features and benefits of your bebek along with the operating procedures. Please thoroughly familiarize this manual before you start driving your bike.

Maintenance is extremely important to let your NEO deliver the maximum performance to you. Please get your NEO maintained from any TVS Authorised Dealer/ PGM / Service outlets.

We are delightful to welcome you into our ever expanding happy family.

Wish you all the very best. Thank you for choosing TVS NEO.

Happy riding,

PT. TVS Motor Company Indonesia

## SPECIFICATIONS

# 1 SPECIFICATIONS

GLOBAL DIMENSIONS	NX	XR & X3i
Total length	1940 mm	
Total width (handlebars)	665 mm	662 mm
Total height	1090 mm	1360 mm
Seat height	760 mm	
Ground clearance	150 mm	140 mm
biodegradability	18°	
wheelbase	1260 mm	1245 mm
Unloaded weight	100 kg	96 Kg
Payload	132 Kg	130 Kg

ENGINE	NX	XR & X3i
Type	Single cylinder 4 stroke air cooled engine	
Bore x stroke	53,5 x 48,8 mm	
Piston displacement	109,7 cc	109,7 cc
Compression ratio	9,3:1	
Carburetor	VM 17 UCAL	

## SPECIFICATIONS

Air filter	Paper filter	
Starter system	Electric start / Kick start	
Lubricating System	Trochoid oil pump	
Quality of engine oil	SAE 20W40 / TVS Tru4 Premium Engine Oil	
Maximum power in kW	6.25 Kw @7500 rpm (8.3 HP)	6.3 Kw @7500 rpm (8.5 HP)
Maximum torque in Nm	8,6 Nm @5500 rpm	8.5 Nm @5500 rpm
Slow engine speed	1400±100	
Candle	BOSCH - UR5DC	
Candle gap	0,6 mm	

TRANSMISSION	NX	XR & X3i
Clutch	Centrifugal clutch - Auto	
Transmission	Constant mesh 4 speed gear box	
Primary reduction	(61/18) 3,388	(61/18) 3,388
Final reduction	(39/15) 2,60	(39/14) 2.786
Transmission report:		
1st speed	(35/12) 2,917	

## SPECIFICATIONS

2nd gear	(26/14) 1,857
3rd gear	(24/18) 1,333
4th speed	(21/20) 1,050
Overall reduction (higher speed)	9,9

FRAME	NX	XR & X3i
Chassis type	Type Underbone	
Hunting angle	260	
Trail	74 mm	
Steering angle	900	
brakes		
Before:	Disc 220 mm	
Back:	Drum 110 mm	

TIRE	NX	XR & X3i
Tire Size		
Before	2,50 x 17"	

## SPECIFICATIONS

	Back	2.75 x 17"
Tire Pressure kg / cm2 (PSI)		
	Before	2,00 kg/cm2 (29 PSI)
	Back	2,25 kg/cm2 (32 PSI)
Suspension		
	Before	Telescopic shock absorbers
	Back	Swing arm with twin shock absorbers.

ELECTRIC	NX	XR & X3i
Ignition system	Digital CDI with twin curve	
Battery Type	12V 4Ah	
Generator	AC 90W Magneto	
Lighthouse	12V 30/30W	
Tail / brake light	12V 18/5W	
Front flashing	12V 10W (2 Nos)	
Rear Blinker	12V 10W (2 Nos)	
Speedometer lamp	12V 3.4W	



## SPECIFICATIONS

Fuel gauge lamp		12V 3.4W
Neutral Indicator Lamp		12V 1.7W
Indicator lamp Flashing		12V 1.7W
Indicator lamp High beam		12V 1.7W
lecono mode indicator	x	12V 1.7W
Engine warm up indicator	x	12V 1.7W
Speed ??position indicator 1-4		12V 1,7W - 4 nos
Horn		12V DC horn - 2A
Position lamp		12V 5W (2 Total)

CAPACITY	NX	XR & X3i
Fuel tank capacity		4 litres
Quantity of engine oil		
	When changing the oil	1000 ml
	When overhauling the engine	1200 ml
Front fork oil quantity		55 ± 2 ml



## PRE DELIVERY CHECK

Please make sure that Pre Delivery Check (PDC) is carried out in your presence before taking delivery of TVS TVS Neo



The check consisting of:

1. Clean and check condition of physical vehicle
2. Check tyre air pressure
3. Check engine oil level
4. Check throttle and brake cable play and adjustment
5. Check drive chain slackness
6. Check Battery / Electrical
7. Start the vehicle and check acceleration
8. Check handle bar freeness
9. Check smoothness of throttle grip
10. Rear view mirror fitment
11. Tightness of bolts and nuts

Date: \_\_\_\_\_

\_\_\_\_\_  
Customer signature

Explain to customer about the following:

1.  (Only for XR & X3i)
2.  (Only for XR & X3i)
3. 
4. Charging the battery
5. Fuel tank capacity
6. Engine oil quantity - 1000 ml

\_\_\_\_\_  
Mechanic signature



## PRE DELIVERY CHECK

Please make sure that Pre Delivery Check (PDC) is carried out in your presence before taking delivery of TVS TVS Neo



The check consisting of:

- 1. Clean and check condition of physical vehicle
- 2. Check tyre air pressure
- 3. Check engine oil level
- 4. Check throttle and brake cable play and adjustment
- 5. Check drive chain slackness
- 6. Check Battery / Electrical
- 7. Start the vehicle and check acceleration
- 8. Check handle bar freeness
- 9. Check smoothness of throttle grip
- 10. Rear view mirror fitment
- 11. Tightness of bolts and nuts

Date: \_\_\_\_\_

\_\_\_\_\_  
Customer signature

Explain to customer about the following:

- 1.  (Only for XR & X3i)
- 2.  (Only for XR & X3i)
- 3. 
- 4. Charging the battery
- 5. Fuel tank capacity
- 6. Engine oil quantity - 1000 ml

\_\_\_\_\_  
Mechanic signature

**IMPORTANT INFORMATION**

# 2

**IMPORTANT  
INFORMATION****Usage**

This bike is designed to use only on road. It is recommended to use only good quality gasoline for your NEO.

**Loading**

This bike is intended to transport you and one pillion. The designed capacity is :

**Maximum load of 130 kg**

It is strictly recommended not to overload by means of additional pillion passenger, or any extra cargo into the bike. Unlimited loading will affect your bike stability and reduce performance significantly.

**Modification**

We have designed this bike with greater care which will

## IMPORTANT INFORMATION

deliver optimum performance to you. Modifying your bike is not recommended. Any kind of modification in this bike will affect the performance and may overrule statutory requirements by the government and violate warranty terms and conditions also.

### **Know the controls**

Before you start driving your bike, we recommend to read this manual carefully. This will give you a very good understanding about your bike and controls and other instruments so that you never make any mistake while driving. Once you read out the manual, habituate yourself to the controls of your bike.

### **Accessories**

While fitting the accessories in your bike we recommend to consult your friendly TVS authorized service outlets who can guide you to select the suitable accessory according to the requirement. Unsuitable accessories which will affect the bike performance is strictly prohibited.

## IMPORTANT INFORMATION

### Item check list

Please check that all the following items have been included in your bike. If anything is missing please contact your friendly TVS service outlets:

Item	Qty
Control key	2 <input type="checkbox"/>
Owners' manual	1 <input type="checkbox"/>
Rear view mirror	2 <input type="checkbox"/>
Tool kit	1 <input type="checkbox"/>

Date : \_\_\_\_\_

### Pre delivery check

Please make sure that Pre Delivery Check (PDC) is carried out in your presence before taking delivery of TVS **NEO**.

Check points:

1. Clean and check condition of physical vehicle
2. Check tyre air pressure
3. Check engine oil level
4. Check throttle, brake cable play and adjustment
5. Check drive chain slackness
6. Check Battery / Electricals
7. Start the vehicle and check acceleration
8. Check handle bar freeness
9. Check smoothness of throttle grip
10. Rear view mirror fitment

\_\_\_\_\_  
Customer signature

\_\_\_\_\_  
Mechanic signature



## IMPORTANT INFORMATION

In this manual, the following symbols are read as follows:



**WARNING** - Disregarding the message might result in serious injury to the rider



**CAUTION** - This message indicates special procedures or precautions to be followed to avoid damage to the vehicle



**NOTE** - This provides further clarification for cleaner understanding of any particular information

### Important Information

We recommend you to carefully read this manual to get clear understanding of your **NEO**. This manual is applicable for all the **NEO** models. Though most of the basic information is common across all variants, differentiation will help in better understanding of both. So please read the information with :

- For **NEO NX**      - For **NEO XR**      - For **NEO X3i**

## KNOW ABOUT YOUR NEO

# 3

## KNOW ABOUT YOUR NEO

### VEHICLE IDENTIFICATION NUMBER (VIN)

#### Frame Number

Frame number is located in the rear side of the frame, between pillion handle and fuel tank. To read the frame number clearly remove the pillion handle by loosening mounting bolts (4Nos).



#### Engine Number

Engine number is engraved on the left side crankcase of engine as shown in fig.



## KNOW ABOUT YOUR NEO

### LOCATION OF PARTS - HANDLE BAR

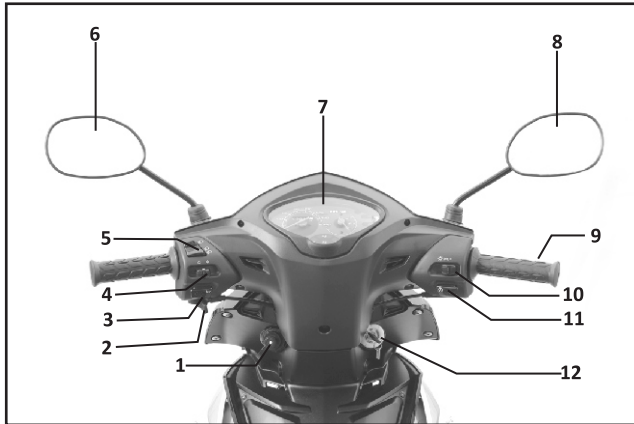

#### **Description:**

1. Socket mobile charger
2. Choke lever
3. Switch horn
4. Turn signal lamp switch
5. High / Low beam switch & Pass by switch
6. Rear view mirror L
7. Speedometer
8. Rear view mirror R
9. Lever front brake
10. Headlamp /position lamp switch
11. Electric starter switch
12. Steering cum Ignition lock

## KNOW ABOUT YOUR NEO

### LOCATION OF PARTS - SIDE VIEW L

#### Description:

1. Position lamp
2. Head lamp assembly
3. Turn signal lamp L
4. Carburettor
5. Gear shifting lever
6. Side stand
7. Center stand
8. Pillion footrest L
9. Seat lock
10. RC lamp assembly



## KNOW ABOUT YOUR NEO

### LOCATION OF PARTS - R SIDE VIEW



### Description:

1. Pillion handle
2. Muffler guard
3. Pillion footrest R
4. Kick starter lever
5. Rider footrest
6. Rear brake pedal
7. Air filter
8. Head lamp beam adjustment
9. Licence plate bracket
10. Mirrors

**KNOW ABOUT YOUR NEO**

**ACCESSORIES NEO NX**

**TVS NEO NX**

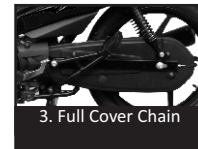
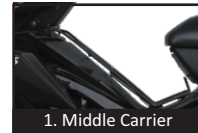

**“The accessories shown in the picture are not part of the standard equipment”**

## KNOW ABOUT YOUR NEO

### LOCATION OF PARTS - SIDE VIEW L

#### Description:

1. Position lamp
2. Head lamp assembly
3. Turn signal lamp L
4. Carburettor
5. Gear shifting lever
6. Side stand
7. Center stand
8. Pillion footrest L
9. Seat lock
10. RC lamp assembly



## KNOW ABOUT YOUR NEO

### LOCATION OF PARTS - R SIDE VIEW

**TVS NEO XR**

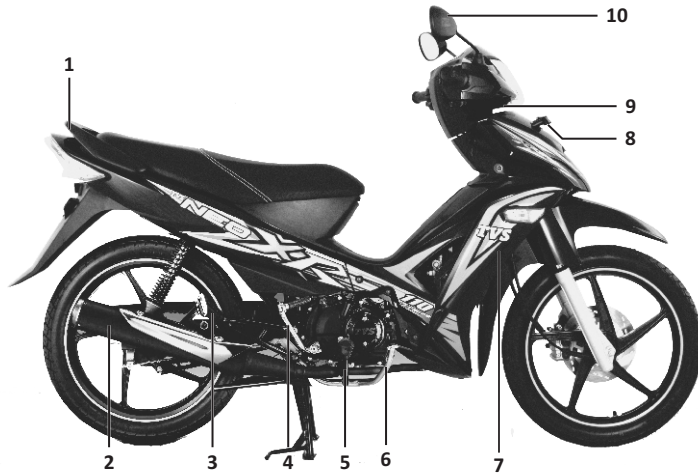

### Description:

1. Pillion handle
2. Muffler guard
3. Pillion footrest R
4. Kick starter lever
5. Rider footrest
6. Rear brake pedal
7. Air filter
8. Head lamp beam adjustment
9. Licence plate bracket
10. Mirrors



## KNOW ABOUT YOUR NEO

### LOCATION OF PARTS - SIDE VIEW L

**Description:**

1. Position lamp
2. Head lamp assembly
3. Turn signal lamp L
4. Carburettor
5. Gear shifting lever
6. Side stand
7. Center stand
8. Pillion footrest L
9. Seat lock
10. RC lamp assembly

**TVS** *NEO* **X3I**



## KNOW ABOUT YOUR NEO

### LOCATION OF PARTS - R SIDE VIEW

**TVS NEO XE1**



### Description:

1. Pillion handle
2. Muffler guard
3. Pillion footrest R
4. Kick starter lever
5. Rider footrest
6. Rear brake pedal
7. Air filter
8. Head lamp beam adjustment
9. Licence plate bracket
10. Mirrors

## KNOW ABOUT YOUR NEO

### IGNITION / STEERING LOCK

TVS Neo comes with a set of two keys. Both can be used to operate ignition lock, steering lock, and seat lock.

Ignition lock has three positions :

#### OFF

In this position, bike cannot be started and key can be removed from the ignition lock.

#### ON

In this position bike can be started by electrically as well as by kick-starting. DC operated equipments will work in this position. Key cannot be taken out from the ignition lock.



**Never leave the ignition switch in ON position. It may drain out the battery faster.**



**This bike has a glow ring around the ignition lock. This gives better visibility of ignition key location in darkness without any power consumption. Provides better visibility of ignition lock in the darkness.**

## KNOW ABOUT YOUR NEO

### LOCK

Neo handle bar can be locked in both left and right directions using steering lock. To lock the steering, turn the handle bar all the way towards Left or Right direction. Push in the key, hold and rotate to LOCK position. Steering locks at this position. Now release the key and takeout.

To unlock insert the key, press and turn to OFF position.



Never make an attempt to move the vehicle with steering locked condition. You may lose balance.

## KNOW ABOUT YOUR NEO

### INSTRUMENT CLUSTER

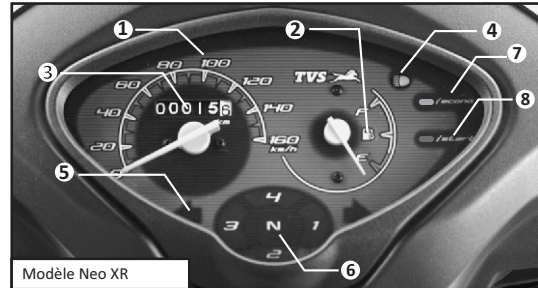
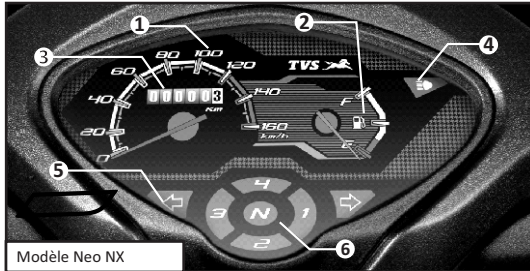

#### 1. Speedometer

Indicates the road speed in kilometers per hour.

#### 2. Fuel gauge

Fuel gauge indicates the level of fuel available in fuel tank.

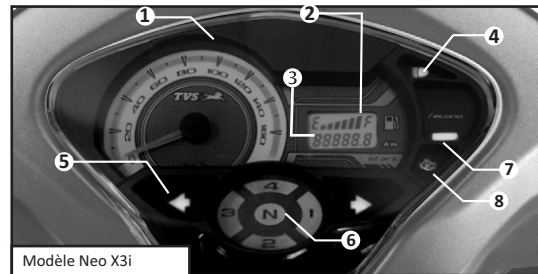

## KNOW ABOUT YOUR NEO

### 3. Odometer

Registers the total distance covered by the bike in kilometers. The last digit denotes one tenth of a kilometer.

### 4. High beam indicator lamp

When the head lamp high beam is 'ON', a blue indicator lamp will glow.

### 5. Turn signal indicator lamps

When the turn signal lamp switch knob is operated to the right or left side, the corresponding turn signal indicator lamp will start blinking.



**For better mileage it is recommended to drive in economy mode.**

### 6. Gear position indicator

Indicates the gear which is in application. When bike comes to neutral position the neutral indicator glows in green colour. Other

### 7. Economy mode indicator

Please see page 37

### 8. Temperature indicator

Please see page 37

## KNOW ABOUT YOUR NEO

gears are indicated in amber colour clockwise.

### HANDLE BAR LEFT SIDE

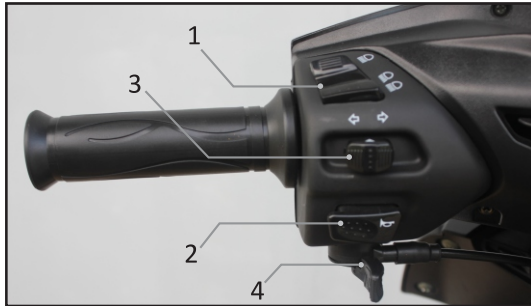

#### 1. Headlamp beam control switch

“” **Low beam:** The symbol denotes the position of Low beam to be used when

vehicles are coming in the front side during night.

“” **High beam:** The symbol denotes the high beam position. This is to put the driving beam while zipping on high ways.

“” **Pass switch:** While overtaking or passing the vehicles during day time this switch is pressed intermittently. This works even when the head lamp switch is in ‘OFF’ position.

#### 2. Horn switch

Press horn switch () to operate the horn.

#### 3. Turn signal switch

Sliding type switch is provided for operating turn signal lamp. Pushing the switch to any

## KNOW ABOUT YOUR NEO

one side will operate the corresponding turn signal lamp and the switch comes back to middle. In this position turn signal indicator lamp in speedometer also glows. Pressing the switch in this position will put off the lamp.

### 4. Choke Lever

Choke lever is mounted below the horn switch. Pull choke lever using left thumb to open the choke. To close the choke just release the lever. It will rest to its original position automatically.



**Always use choke for morning starting. This will make your starting easy. Do not open throttle grip when choke is ON.**

## HANDLE BAR RIGHT SIDE

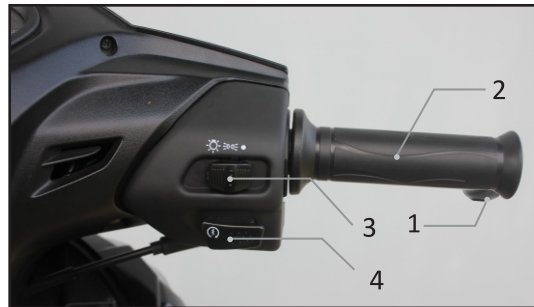

### 1. Front brake lever

Front brake is applied while pressing this lever gently towards throttle grip. Brake lamp will glow on the application of front brake.



## KNOW ABOUT YOUR NEO

### 2. Throttle grip

Rotating the grip towards you will raise the engine rpm. To reduce the engine rpm just leave the throttle.

### 3. Head lamp control switch

The switch to operate head lamp is given on right side. It has three positions as shown below:

**POSITION LAMP (  )** : In this position, two parking lamps on the head lamp, tail lamp and speedometer lamps will glow.

**ON (  )** : In this position head lamp, tail lamp and speedometer lamps are on.

**OFF ( ● )** : Head lamp, tail lamp and speedometer lamps are off despite of engine is running.

### 4. Starter switch ( )

Starter switch is provided just below the head lamp control switch. To start the engine electrically just press this button. Release button once the engine is started.



For morning cold starts, it is recommended to use kick starter to avoid excessive drain of battery power.



Whenever bike is in gear, do not keep throttle wide open and start the bike. This may move your bike forward suddenly.

## OTHER CONTROL INSTRUMENTS

### Rear Brake Pedal

Rear brake pedal is located on the right side of

## KNOW ABOUT YOUR NEO

bike. Press down the rear brake pedal with foot to apply rear brake. Brake lamp glows while applying rear brake.

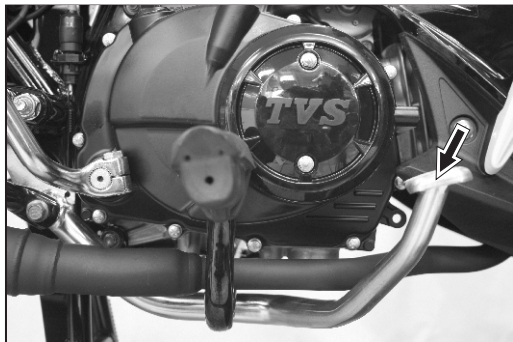

Brakes are of personal safety items and should be maintained in proper condition.



Always apply both front and rear brake simultaneously for effective braking.

### Gear shift lever

TVS Neo is equipped with rotary cam gear shift mechanism. It has a toe and heel gear shift lever for shifting gear. Gear shift lever is located on the left side of bike.

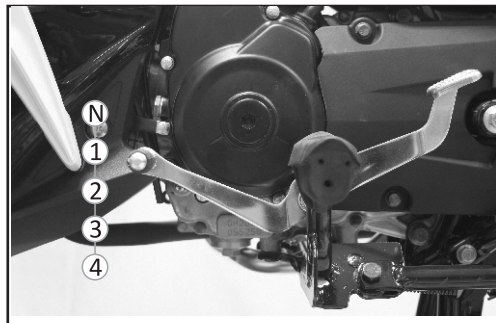

## KNOW ABOUT YOUR NEO

Press down the gear lever once with toe to engage gears in the ascending order. To shift to lower gear press gear lever rear end using the heel. Only in idling condition pressing



**Do not drive the vehicle with partially pressed gear shift lever, which results in loss of power.**

### In Idling

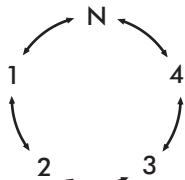

### In Running

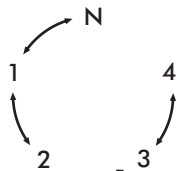

down from 4<sup>th</sup> gear will put the gear in neutral position, whereas this is not possible while running.



**Always keep the transmissions in neutral position while starting the bike.**

### Kick Starter Lever



## KNOW ABOUT YOUR NEO

Kick starter lever is located on the right side of the bike. Sit on the vehicle and kick start the engine, keeping ignition switch in 'ON' condition and transmission in neutral position.

### **Center stand and side stand**

Neo is equipped with both center stand and side stand. To place the vehicle on center stand, press the extension rod which is below the pillion footrest holder. Slightly lift the vehicle while both legs of center stand touch the ground firmly. To put the vehicle on side stand just release it from the bike and park the bike.

To release side stand, push it to the fullest position.



### **Seat Opening**

Seat can be opened using the control key provided. Seat lock is located on the rear fender. Insert and turn the key clockwise to

## KNOW ABOUT YOUR NEO

open the seat. Lift up the seat to access the under seat compartment.



### Fuel filling

After opening the seat, release fuel tank cap by turning it to counter clock wise direction. Now take out the tank cap and place it on the

pillion handle seat lock hole so that you need not to hold the cap in hand.



### TOOL KIT

Tool kit is located under the seat and strapped with the seat base using a rubber ring.

## KNOW ABOUT YOUR NEO



Presence of tool kit in the vehicle will help you in unavoidable circumstances to tackle minor maintenance actions.

### **The tool kit contains following tools:**

1. Combination screw driver  
( bit no. 2 and flat)

2. Phillips screw driver bit no. 3

3. Screw driver handle

4. 8-10 open end spanner

5. 10-12 open end spanner

6. 14-17 open end spanner

7. 16-17 tubular spanner

8. Combination tool.

9. Tool bag

The different applications of combination tool are illustrated in following figures.

**KNOW ABOUT YOUR NEO**

Open end to adjust throttle cable play.



Open end to open & tighten dipstick oil.

# 4

## FEATURES & BENEFITS

### **Duralife** ENGINE

#### **Duralife engine**

TVS Neo is powered with low friction over square engine. Which is highly efficient and proven long life engine. This gives you better pickup, higher mileage and long life durability.

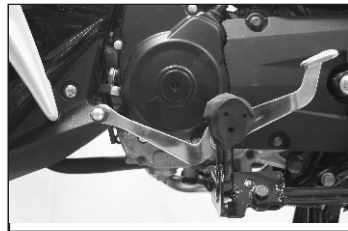

### **ISPACE**

#### **Utility Box**

An extra large 9 litres space to accommodate a batok helmet, jacket and gloves inside.





**FEATURES & BENEFITS**



**Economy mode (A)**

A Green indicator in speedometer guides the customers, while driving that he/she is driving in economy zone where he can save significant amount of fuel and money too.

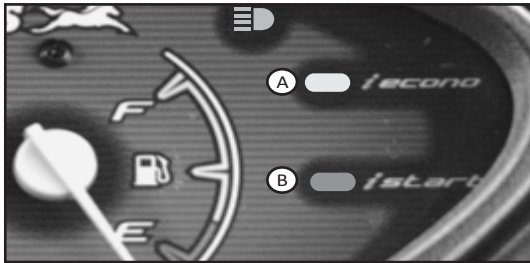

**Warm up indicator (B) **

Yet another feature to indicate the warmness of your bike engine. This will blink for few seconds and start glowing continuously until the oil temperature reaches 25°C or two minutes whichever comes earlier.



## FEATURES & BENEFITS

### Socket mobile charger

Neo has a socket to charge your hand phone. Open the socket cap and insert the adaptor and charge your hand phone. After charging close the cap.

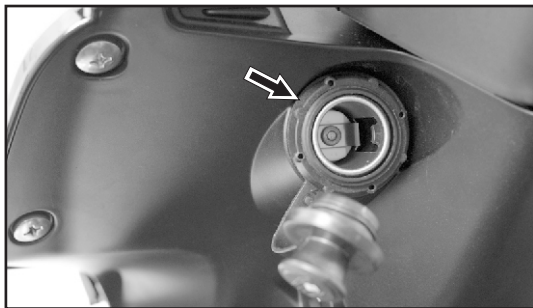

It is recommended to charge hand phone while the engine is running to avoid unnecessary drain of battery charge.



The socket is a provision for the charging. Appropriate selection of charging adaptor with respect to your hand phone lies under your responsibility.



Use this socket only to charge hand phone. Use of other accessories like cigarette lighter, torch light and walkman etc. are not allowed. This may seriously affect the electrical system.

## FEATURES & BENEFITS

### Glow ring

Ignition switch top cap has a glow ring which glows in the darkness. This is not powered by any external source. It works on the light absorption. Thus the glowing brightness depends on the exposure of glow ring to light.

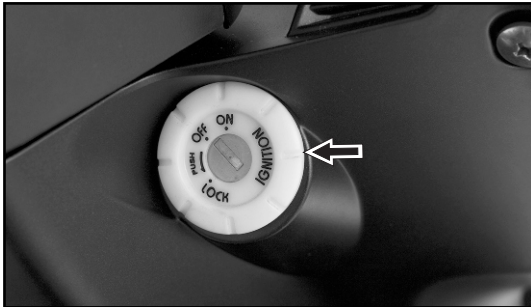

# 5 MAINTENANCE

Maintenance is most important for any kind of bike to keep it in better condition so that it delivers maximum performance. In this chapter you will find the maintenance schedule which will indicate the interval for maintenance activities. Adhering to the schedule will help to keep your vehicle in better condition.

Since your vehicle contains many moving parts, maintenance plays a vital role to keep all the moving parts in order so that it works perfectly without any abnormal wear and tear. Ignoring maintenance will result in rapid wear and tear of parts. To obtain maximum benefit we recommend to service your bike at any of TVS Authorised dealer / PGM / Service outlets.

Periodic maintenance may require replacements of few parts. Whenever replacing parts of your it is recommended to use TVS Genuine parts. PT TVS Motor strongly recommends to service your vehicle at any of TVS Authorised dealer, PGM & Service outlets.

## MAINTENANCE

### MAINTENANCE SCHEDULE

Item	Period (km)	1 month	4 month	7 month	10 month	13 month
		1000	4000	7000	10000	13000
Engine oil		R	R	R	R	R
Oil filter		C	C	C	C	C
Air filter		---	I&C	I&C	I&C	I&C
Carburettor Assy		---	---	C	---	C
Spark plug		I&C	I&C	I&C	I&C	R
Clutch play at cover clutch		I&A	I&A	I&A	I&A	I&A
Valve & tappet clearance		I&A	I&A	I&A	I&A	I&A
Fuel hose		I	I	I	I	I
Front brake		I&A	I&A	I&A	I&A	I&A
Rear Brake		I&A	I&A	I&A	I&A	I&A
Front disc brake oil level		I&T	I&T	I&T	I&T	I&T
Front disc pad		I	I	I	I	I
Brake hose		I	I	I	I	I
Steering play		I&A	I&A	I&A	I&A	I&A

R - Replace; I - Inspect; C - Clean; A - Adjust; L - Lubricate; T - Topup

## MAINTENANCE

### MAINTENANCE SCHEDULE

Item	Period (km)	1 month	4 month	7 month	10 month	13 month
		1000	4000	7000	10000	13000
Tyres		I	I	I	I	I
Wheel bearing		I	I	I	I	I
Brake switches		I	I	I	I	I
Front fork		I	I	I	I	I
Rear shock absorber		I	I	I	I	I
Throttle switch		I&A	I&A	I&A	I&A	I&A
Headlamp beam		I&A	I&A	I&A	I&A	I&A
Drive chain		C,L&A	C,L&A	C,L&A	C,L&A	C,L&A
Center & side stand		---	L	I	L	I
Throttle grip		---	L	I	L	I
Throttle cable play		I&A	I&A	I&A	I&A	I&A
All control cables		I,A&L	I,A&L	I,A&L	I,A&L	I,A&L
All switches and bulbs		I	I	I	I	I
Battery electrolite level		I&T	I&T	I&T	I&T	I&T
Battery	Check & Recharge if necessary					

R - Replace; I - Inspect; C - Clean; A - Adjust; L - Lubricate; T - Top up

## MAINTENANCE

### MAINTENANCE SCHEDULE

Item	Period (km)	16 month	19 month	22 month	25 month	28 month	31 month	34 month
		16000	19000	22000	25000	28000	31000	34000
Engine oil		R	R	R	R	R	R	R
Oil filter		C	C	C	C	C	C	C
Centrifugal filter		Clean at every 18000 Kms						
Air filter		I&C	I&C	I&C	I&C	I&C	I&C	R
Head cylinder / piston		Decarbonise at every 18000 Kms						
Carburettor Assy		---	C	---	C	---	C	---
Spark plug		I&C	R	I&C	I&C	R	I&C	I&C
Clutch play at cover clutch		I&A	I&A	I&A	I&A	I&A	I&A	I&A
Valve & tappet clearance		I&A	I&A	I&A	I&A	I&A	I&A	I&A
Fuel hose		I	I	I	I	I	I	I
Fuel filter(Inside the fuel tank)		Clean at every 18000 Kms, replace if required						
Front brake		I&A	I&A	I&A	I&A	I&A	I&A	I&A
Rear Brake		I&A	I&A	I&A	I&A	I&A	I&A	I&A
Front disc brake oil level		I&T	I&T	I&T	I&T	I&T	I&T	I&T
Front disc pad		I	I	I	I	I	I	I

R - Replace; I - Inspect; C - Clean; A - Adjust; L - Lubricate; T - Topup

## MAINTENANCE

### MAINTENANCE SCHEDULE

Item	Period (km)	16 month	19 month	22 month	25 month	28 month	31 month	34 month
		16000	19000	22000	25000	28000	31000	34000
Brake hose		I	I	I	I	I	I	I
Steering play		I	I	I	I	I	I	I
Tyres		I	I	I	I	I	I	I
Wheel bearing		I	I	I	I	I	I	I
Brake switches		I	I	I	I	I	I	I
Front fork		I	I	I	I	I	I	I
Rear shock absorber		I	I	I	I	I	I	I
Throttle switch		I&A	I&A	I&A	I&A	I&A	I&A	I&A
Headlamp beam		I&A	I&A	I&A	I&A	I&A	I&A	I&A
Chain		C,L&A	C,L&A	C,L&A	C,L&A	C,L&A	C,L&A	C,L&A
Center & side stand		---	L	I	L	I	L	I
Throttle grip		L	I	L	I	L	I	L
Throttle cable play		I&A	I&A	I&A	I&A	I&A	I&A	I&A
All control cables		I,A&L	I,A&L	I,A&L	I,A&L	I,A&L	I,A&L	I,A&L
All switches and bulbs		I	I	I	I	I	I	I
Battery electrolite level		I&T	I&T	I&T	I&T	I&T	I&T	I&T
Battery		Check at every service & Recharge if necessary						

R - Replace; I - Inspect; C - Clean; A - Adjust; L - Lubricate; T - Topup



**MAINTENANCE****DO IT YOURSELF****Battery**

Battery is located under the utility box. To access the battery remove seat and utility box.

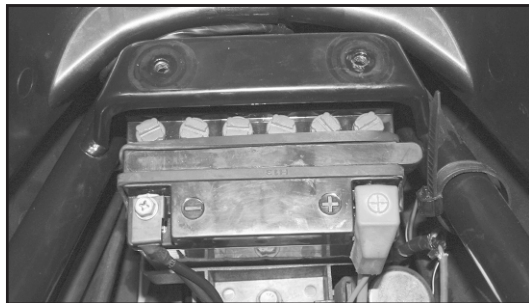

To have better battery performance and longer battery life, customers are requested to follow the steps given below:

1. Cold starting by using kick starter.
2. Charge the battery at every month / service.
3. Do not add more electrical accessories.

## MAINTENANCE

### Fuse

Fuse is located just below the utility box, to access the open the seat. Inside the utility box a lid is provided to access the fuse. Replace fuse with the spare fuse given in the fuse box if fuse is blown.



**Fuse 10 A**

### Air filter

Neo air filter has a paper filter element. After removing the side panels, remove the air filter from the bike. Separate the air filter cover using a screw driver and take out the filter element. Clean the paper element using a compressed air as shown. After cleaning,

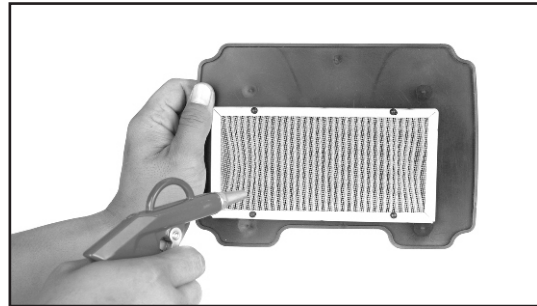

## MAINTENANCE



Do not blow the compressed air directly on the element. Hold the compressed air at an angle of 45° with moderate pressure so that the filter element is not torn.



Do not clean the filter element with kerosene or gasoline. It will damage the filter.

reassemble filter element and cover air filter in the reverse order.

### Carburettor

Carburettor is located on left side of the bike. Idling rpm can be adjusted by turning the idle adjustment screw. Turn the screw in clockwise direction to increase the rpm and counter clockwise direction to reduce the



rpm. Idle rpm should be within the limit as specified.



It is recommended not to disturb the air screw when the engine performance is good.

## MAINTENANCE

### Spark plug

Remove spark plug using the spark plug spanner and screw driver given in the tool kit.

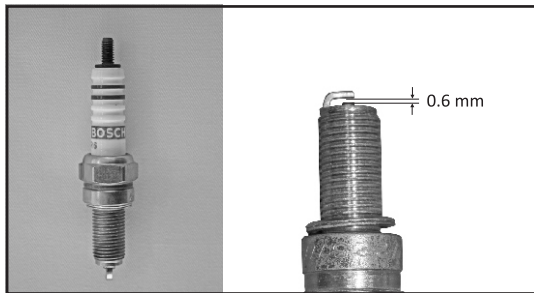

Clean the spark plug and inspect the electrode gap. If it is not as per the specification, adjust to the specified electrode gap.

**Spark plug electrode gap : 0.6 mm**

**Recommended spark plug BOSCH - UR5DC**



It is advisable to tighten the spark plug by hand till the end and then tighten with the spark plug spanner.



Do not over tighten or cross thread the spark plug as the aluminium thread of cylinder head will be damaged.

### Engine oil

Check the engine oil level frequently and replace it periodically.

#### Engine oil level check:

1. Park the bike firmly on center stand. If vehicle is driven recently, allow it to cool for few minutes so that all oil come back to the sump.

## MAINTENANCE

- Remove gauge oil level (Dipstick) from the cover clutch.
- Wipe off the oil from dipstick and insert to the oil filling orifice. Now take out and check for engine oil level. The level should

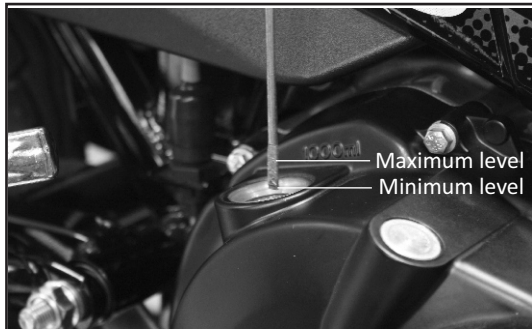

Running engine with very low engine oil will severely damage the engine components.

- be between minimum and maximum level.
- Repeat previous steps once again to confirm oil level. Reassemble the dipstick and tighten.

### Engine oil replacement:

- Warm up the engine for few minutes. Repeat the first two steps of oil level check.
- Remove the oil drain plug using a 17 mm spanner. Carefully drain the oil into a pan/tray. While removing drain plug filter oil also comes out along with.
- Clean the filter oil with compressed air and refit.
- Reassemble the drain plug.

## MAINTENANCE

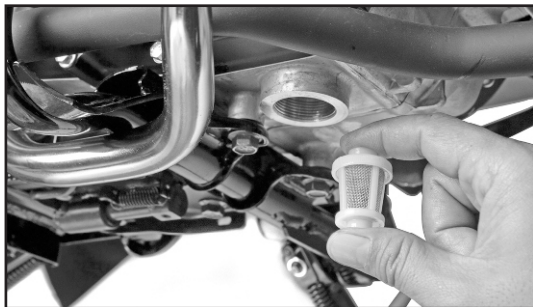

5. Fill fresh engine oil as specified in this manual.

**Oil recommended :  
SAE 20W40/TVS TRU4 Premium Engine oil**

6. Repeat the last two steps of oil level check.

### Brakes

#### Front brake(Drum)

1. Measure front brake free play at the end of front brake lever as shown. The play measured should be between 10-15 mm.

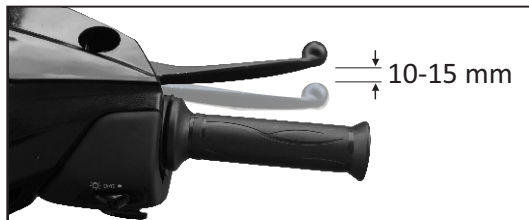

**Front brake free play : 10 -15 mm**

2. Specified free play can be obtained by turning the adjuster nut in or out.

## MAINTENANCE

- Turn the adjuster clockwise to reduce the free play and counter clockwise to increase the free play.

### Front brake(Disc)

Front disc brake does not require any adjustments in terms of free play. It has self adjusting brake pads. But brake fluid level in



reservoir to be checked periodically.

- Check the brake fluid level through the cut given in cover handle rear. The level must be above the mark 'lower' on the master cylinder.



**Check the brake fluid level only when the master cylinder is parallel to the ground.**

- If the level is below the lower mark, check for any leakage in the brake system and refill.
- While applying brake, if you feel it is more spongy or ineffective, it may be due to the entry of air into the brake system. For this you need to carry out air bleeding.

Contact TVS Motor Company authorised service outlets for any service like air bleeding , brake oil refilling etc., whenever required.

## MAINTENANCE

### Rear brake

1. Measure the rear brake pedal free play between initial position of brake pedal and the brake pedal fully pressed position.
2. Adjust the brake adjuster nut to increase or decrease the pedal free play. The play should be within the specification.



Rear brake free play : 15 -25 mm

### Brake shoe wear indicator

When brake is applied, the index mark (A) on the cam brake should be within the range on the wear limit indicator (B) on the brake panel assembly.

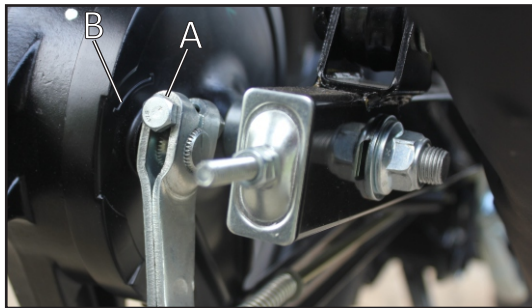

Replace the brake shoes, if the wear indicator crosses the wear limit. Replace brake shoes as a set.



## MAINTENANCE

In case, the mark crossing the wear limit, consult the nearest TVS Motor Company Authorised service outlet.

### Tyre

#### Tyre pressure:

Check tyre pressure at least once in a week if not more frequently. Insufficient tyre air



pressure not only hasten tyre wear, but also affects the stability of the bike seriously.

Under inflated tyre makes smooth cornering difficult and over inflated tyre decreases the tyre contact with the road which can lead to skidding and loss of control. Ensure that the tyre pressure is within the specified limits at all times.

Tyre Pressure	
Front	2.00 kg/cm <sup>2</sup> (29 psi)
Rear	2.25 kg/cm <sup>2</sup> (33 psi)



The tyre inflation pressure and the tyre condition are extremely important for the performance and safety of the rider. Check the tyres more frequently for inflation pressure as well as for wear pattern on it.

## MAINTENANCE

### Tyre tread condition

Operating the bike with excessively worn tyres will decrease riding stability and can lead to loss of control.

Hence It is recommended to replace the tyre when tyre wears off to the tyre wear indicator level (indicated by mark “ $\Delta$ ” on the tyre).



Use of tyre other than the standard may cause instability. While reassembling tyre, ensure that the arrow mark (A) provided on the tyre facing the direction of wheel rotation.

### WHEEL REMOVAL

#### Front wheel (Drum brake)

1. Remove the front wheel axle nut using a

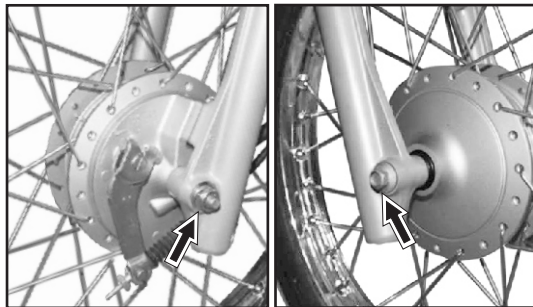

## MAINTENANCE

17mm spanner. Hold the other end of the axle with 14mm spanner if required.

2. Pull out the axle and take out the wheel assy. Takeout the spacer from wheel assy.
3. Separate the brake panel and takeout the wheel assy.
4. Reverse the above steps to reassemble the front drum wheel.

### Front wheel (Disc brake)

1. Remove the front wheel axle nut using a 17mm spanner. Hold the other end of the axle with 14mm spanner if required.
2. Pull out the axle and take out the wheel assy along with the disc front brake, spacer complete and hub drive speedo.
3. Keep some cushion in between the disc



brake pads to avoid binding.

4. Reverse the above steps to reassemble the front disc wheel.

### Rear wheel

1. Remove the nut rear brake adjuster and disconnect the rod, remove split pin and nut from the torque link rear mounting.

## MAINTENANCE

2. Remove the rear wheel axle nut using a 17mm spanner. Hold the other end of the axle with 14mm spanner if required.
3. Pull out the axle and take out the wheel assy. Takeout the spacer from rear brake panel.
4. Separate the brake panel from the wheel assy.
5. Separate the drum sprocket and the spacer from the rear wheel assembly and take out the rear wheel complete.
6. Reverse the above steps to reassemble the rear wheel.
7. Adjust the chain after reassembly.

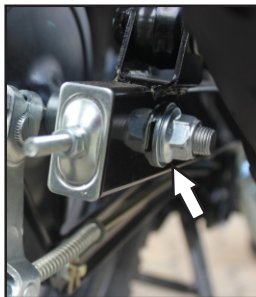

### Chain adjustment

1. Loosen the rear wheel axle nut.
2. Loosen the lock nut(A&B) first and adjust the chain adjusting nuts (C&D)on both L and R side equally in or out looking at the line mark (E&F).
3. The chain free play should be between 20-25mm.
4. In this position leave adjuster and tighten both the lock nuts(A&B).

## MAINTENANCE

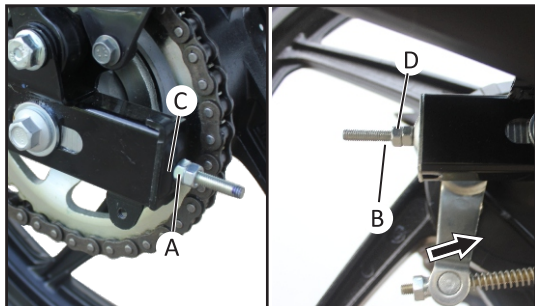

5. Tighten the rear wheel axle nut.



Maintain equal number of line marks on both the chain adjusters.



It is advised to Lubricate chain assy after every water service for better chain life.

### Head lamp bulb replacement

1. Loosen CRPH screws M5x16 (4Nos) from the cover main pipe center front using a phillips screw driver.



2. Loosen Hex bolts (2 Nos) from the licence plate bracket mounting and separate cover frame head.
3. Loosen Screw (4 Nos) from Cover Handle Rear

## MAINTENANCE



4. Disconnect the headlamp socket from the wiring. Dislocate boot from the headlamp.
5. Pull out the headlamp bulb connector and take out the bulb headlamp after dislocating the clip bulb holder from the bracket.
6. Replace the bulb with a new one.



Always use only the recommended type and specified rating of bulbs.



After reassembling headlamp assembly it is advised to readjust the headlamp beam.



Neo X3i is fitted with HS1 Halogen bulb. Do not hold the bulb at its tip and glass region, as it affects the bulb life and performance significantly .

7. Follow the removal procedure in the reverse order for reassembly.

### Head lamp beam adjustment

Head lamp beam can be adjusted by loosening the Bolt (1Nos.) provided at the bottom mounting of headlamp. Adjust the headlamp assy as required and tighten the screws.

## MAINTENANCE

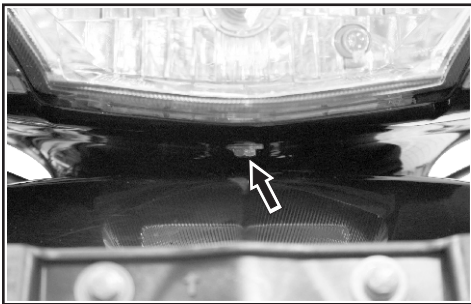

### Tail lamp bulb

Neo Tail lamp bulb can be replaced by removing lens tail lamp. Removal procedure is as follows:

1. Remove screws (2Nos.) from the RC lamp.



Always use only the recommended type and specified rating of bulbs.

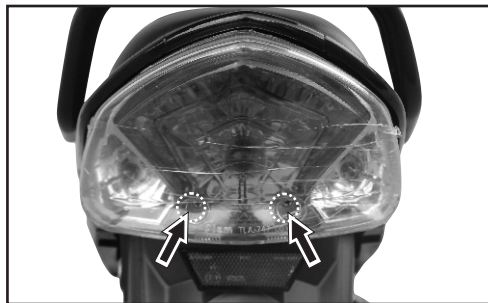

\*Photo prise à partir de Neo NX

2. Take out the lens.
3. Now tail lamp bulb is accessible.
4. Replace the tail lamp bulb with a new one.
5. Reverse the above steps for reassembly.

## SERVICE RECORD

# 6

## SERVICE RECORD

Your Neo has nineteen periodic services. To keep the record of the maintenance history, service record sheet is attached in this owners manual book. Please have the service record sheet filled by the dealer who is carrying out the maintenance service of your Neo.

For availing all services, please take your vehicle along with this manual to any of your friendly TVS dealer or any TVS authorised outlet. The dealer will perform the applicable periodic service of your Neo for your satisfaction. For your record, the dealer will affix their stamp on service record sheet.

Periodic maintenance always helps good performance of your bike and the services are planned to keep your Neo delivers you the optimum performance.



## SERVICE RECORD

Please remember that after all the services are over, periodic servicing of your vehicle at the same intervals as specified in the maintenance schedule or at appropriate intervals depending upon the extent of use will make your Neo at best level of performance.

**SERVICE RECORD****SERVICE RECORD SHEET**

<b>NO</b>	<b>SERVICE SCHEDULE</b>	<b>KM READING</b>	<b>JOB CARD / DATE</b>	<b>SERVICING DEALERS STAMP</b>
1	1st service 1 month or 1000 km whichever occurs earlier			
2	2nd service 4 months or 4000 km whichever occurs earlier			
3	3rd service 7 months or 7000 km whichever occurs earlier			
4	4th service 10 months or 10000 km whichever occurs earlier			
5	5th service 13 months or 13000 km whichever occurs earlier			

**SERVICE RECORD****SERVICE RECORD SHEET**

<b>NO</b>	<b>SERVICE SCHEDULE</b>	<b>KM READING</b>	<b>JOB CARD / DATE</b>	<b>SERVICING DEALERS STAMP</b>
6	6th service 16 months or 16000 km whichever occurs earlier			
7	7th service 19 months or 19000 km whichever occurs earlier			
8	8th service 22 months or 22000 km whichever occurs earlier			
9	9th service 25 months or 25000 km whichever occurs earlier			

**SERVICE RECORD****SERVICE RECORD SHEET**

<b>NO</b>	<b>SERVICE SCHEDULE</b>	<b>KM READING</b>	<b>JOB CARD / DATE</b>	<b>SERVICING DEALERS STAMP</b>
11	11th service 31 months or 31000 km whichever occurs earlier			
12	12th service 34 months or 34000 km whichever occurs earlier			
13	13th service 37 month or 37000 km whichever occurs earlier			
14	14th service 40 months or 40000 km whichever occurs earlier			
15	15th service 43 months or 43000 km whichever occurs earlier			

## SERVICE RECORD

### SERVICE RECORD SHEET

NO	SERVICE SCHEDULE	KM READING	JOB CARD / DATE	SERVICING DEALERS STAMP
16	16th service 46 months or 46000 km whichever occurs earlier			
17	17th service 49 months or 49000 km whichever occurs earlier			
18	18th service 52 months or 52000 km whichever occurs earlier			
19	19th service 55 months or 55000 km whichever occurs earlier			

# PT TVS Motor Company Indonesia

Office Sales and Marketing :

Wirausaha Building 3rd Floor, HR Rasuna Said Road Cluster Kav. C-5  
Kuningan, Jakarta 12920, Indonesia

Phone: +62 21 300 20570, Fax: +62 21 300 20576 [www.tvsmotor.co.id](http://www.tvsmotor.co.id)

Factory:

Surya Cipta City of Industry, Surya Madya Blok 1-30  
Kutanegara Village, Ciampel, Karawang 41361, West Java, Indonesia

Edition December 2019