

EXPORT

*Apache*

**RTR 160**

HYPER EDGE

## **OWNER'S MANUAL**

**TVS Motor Company Limited**

---

Customer's Name and Address.....

.....

.....

Frame Number:.....Engine Number.....

Key Number.....Colour.....

Date of Sale.....Registration Number.....

Selling Distributor / Dealer's Name & Address Stamp :

.....

.....

.....

Dear Customer

Congratulations on the taking home the new Apache RTR 160 HYPER EDGE. Rest assured you can look forward to exciting times ahead. And you will know what we are hinting at every time you gun that throttle that is meant to live up to its name - Racing Throttle Response 160.

The priority in every step of the RTR 160 HYPER EDGE development has been **Performance first**. Every system, every detail and every component has been studied and pared down to its essence and performance increased to the maximum. If it didn't make the RTR 160 HYPER EDGE lighter, faster or deliver quicker lap times on our Racetrack, it wasn't considered.

The result: the RTR 160 HYPER EDGE is the fastest motorcycle with the highest power-to-weight ratio of any sport bike we have ever made. It is the lightest, fastest stopping, quickest lapping TVS bike in history. For the first time **TVS Racing**'s Dirt and Road racing technology have been combined to create a racing bike that is **Street Legal**, but just barely. The results are stunning.

### **DESIGNED BY THE RACE TRACK**

The look and stance of the RTR 160 HYPER EDGE were designed by the combination of race track technology, track-derived components at our Apache Racing Group. The bike's striking aerodynamic shape naturally embraces its Racing Ergonomics. The all new Tank Scoops and new Data logging facilities which display Top speed and 0 - 60 lap time are the seen for the first time.

Also this Owner's Manual has all details to ensure your bike is in top notch race ready condition.

So get astride and burn rubber on every road you hit. Every road will now seem a race track.

Enjoy Riding!

**TVS MOTOR COMPANY LIMITED**

This manual should be considered as a permanent part of the motorcycle and should remain with the motorcycle when resold or transferred to a new owner.









All information, illustrations, photographs and specifications contained in this owner's manual are based on the latest product information available at the time of this publication. TVS Motor Company Limited may, however, incorporate modifications or improvements on its vehicles at any time without notice, and therefore, in such events it is possible that the relevant part of the owner's manual does not apply to your vehicle.

Prior permission of TVS Motor Company Limited is required for quoting, copying or reproducing any part of this owner's manual.

**Note**

*Accessories shown in the picture may not be part of the standard equipment.*

*Pictures shown in this manual are of Apache RTR 160 HYPER EDGE Rear Drum brake model until it is specified*

	<b>Safety information</b>	<b>01</b>
	<b>Running-in information</b>	<b>02</b>
	<b>Safe riding tips</b>	<b>03</b>
	<b>Know your Apache RTR 160 HYPER EDGE</b>	<b>07</b>
	<b>Riding your Apache RTR 160 HYPER EDGE</b>	<b>26</b>
	<b>Maintenance</b>	<b>31</b>
	<b>Service Record Sheet</b>	<b>52</b>
	<b>Technical specifications</b>	<b>54</b>

# *Apache*

RTR 160

Operating this vehicle safely is an important responsibility of the rider. To help you make decisions about safety, we have provided operating procedure and other information in this manual. This information alerts you on potential hazards that could hurt you or others. Since it is not possible to warn you about all hazards associated with operating or maintaining the vehicle, you must use your own judgement.

You will find important safety information in following form in this manual. These words carry the following connotations:

### Warning

*Disregarding this message might result in injury to the rider.*

### Caution

*This message indicated special procedures or precautions to be followed to avoid damage to the vehicle.*

### Note

*This message provides further clarification for clearer understanding of any particular information.*

The first 1000 km is a crucial part of your motorcycle. Proper running-in operation during this period helps in ensuring a **maximum life** and **smooth performance** of your motorcycle.

The reliability and performance of your motorcycle depends on the special care and restraint exercised during the running-in period. It is especially important that you avoid operating the engine in high speed (RPM), which could expose the engine parts to excessive stress. Maximum recommended speed during the running-in is:

**Maximum 50 kmph speed upto 1000 km** (vary the engine speed for better mating of parts).

The first service at 500 ~ 750 km is most important. During running-in period all the engine components and other parts will have set in. All adjustments to be restored, all fasteners to be tightened. Engine cum transmission oil to be replaced. Timely performance of the first free service will ensure optimum service life and performance from the engine.



### Caution

*Replacing the engine cum transmission oil during first free service is most important for better life of engine. Always use TVS TRU4 PREMIUM, 4T oil for better performance and life.*



### SAFE RIDING RECOMMENDATIONS

Any two wheeler riding requires some precautions to be taken to ensure the safety of the rider, pillion rider and other road users. These precautions are:

#### Familiarise yourself with new Apache RTR 160 HYPER EDGE

Riding skill and your mechanical knowledge form the foundation of safe riding practices. We suggest you to practice riding Apache RTR 160 HYPER EDGE in a low-traffic condition until you are thoroughly familiar with your vehicle and its controls. Remember practice makes you perfect.

#### Riding apparel

Loose, fancy clothing can be uncomfortable and unsafe when riding a two-wheeler. Choose good quality two wheeler riding apparel.

#### Know your limits

Ride within the boundaries of your own skill at all times. Knowing these limits and staying within them will help you avoid accidents.



#### Warning

*Two wheeler safety equipment starts with a safety helmet of good quality. One of the most serious injuries that can happen is a head injury. Always wear good quality helmet. You should also have good suitable eye protection.*

## SAFE RIDING TIPS



### Posture

Proper vehicle riding starts with proper posture.

1. Keep your elbows inside close to the body and flexible.
2. Hold your arms at an angle of about 120°.
3. Hips should be in a position so that arms and shoulders are relaxed.
4. Look widely instead of gazing at one point.
5. Relax to guard against a sudden impact.
6. Hold the tank tightly with knees.
7. Point the toes straight ahead.

### Cornering

When cornering, centrifugal force works in a direction perpendicular to the direction in which the vehicle is moving. Centrifugal force increases in proportion with speed and the radius of the corner.

During cornering, reduce speed so as to lessen the effects of centrifugal force. By all means, avoid abrupt application of brakes or sudden steering.



### Warning

*One-hand riding is dangerous. Keep both hands firmly on the handle bar and both feet securely on the foot rest. Under no circumstances should both the hands be removed from the handle bar, as it is very dangerous.*

***Avoid use of mobile phones while riding as it could lead to fatal accident.***

*Do not downshift the gear in the midst of cornering. Slow down to a safe speed before negotiating a corner. If this is the first time that you are riding a vehicle of this type, we suggest that you practice on a safe, open area to become thoroughly familiar with the operation of the vehicle.*

### Braking

For safe riding, it is very important to master the braking techniques.

1. Close / release the throttle.
2. Hold the vehicle upright as you apply the brake.
3. Progressive application of brakes is safer.
4. Never depress the clutch lever while braking at higher speeds.
5. **Apply both the brakes.**
6. Riding down hills, while cornering and wet roads close throttle and down shift the gear to take advantage of gearbox and engine which acts as an additional brake. This will avoid the loss of control over the vehicle due to over speed.

### Causes for poor braking

1. If the brake shoes / pads or drum / disc are worn out or if there is water or oil on them, sufficient friction does not develop and brakes do not work well.

2. Even when the brake works normally, if the road surface is wet or the tyre surface is worn-out, tyres do not take a firm hold on the surface, increasing the stopping distance.
3. Approximately 60% braking effect is from front brake. **Non-usage of front brake causes poor braking.**



### Warning

*As the vehicle speed increases, the stopping distance also increases progressively. Be sure that, you have sufficient distance between you and the vehicle or obstruction ahead of you.*

*Using only the front or rear brake is dangerous and can cause skidding and loss of control. Apply both the brakes together and with great care on a wet road or other slippery surfaces. Any abrupt braking on slippery or irregular roads can cause loss of rider control.*

### ACCESSORY INSTALLATION AND SAFETY TIPS

Use extreme caution while selecting and installing the accessories for your motorcycle.

The addition of **unsuitable accessories can lead to unsafe operating conditions**. Your friendly Distributor / Dealer will assist you in selecting quality accessories and installing them correctly.

While selecting the accessories, make sure the accessories **should not obstruct lighting, steerability, suspension level and ground clearance**. Please ensure that, if the tank cover is used, it not getting en-trapped between fuel tank and fuel tank cap.

**Additional electrical equipments and controls should not exceed the specified electrical system load of the vehicle (capacity of battery and magneto).**

### EMISSION CONTROL

All the TVS vehicles are tested in the factory for optimum fuel efficiency and lowest possible CO levels.

**Do not disturb the Carburettor settings as this may lead to higher fuel consumption and also higher CO levels.**

If the vehicle needs any adjustments, please consult nearest TVS Motor Company Authorised Distributor / Dealer or Authorised Service Centers.

While adequate care is exercised at the factory to ensure that the emissions are within the limits, it is essential for the owner to always maintain the motorcycle in good condition by getting it periodically checked and serviced by TVS Motor Company Authorised Distributor / Dealer or Authorised Service Centers so that the emission and fuel consumption levels are maintained as per norms.



Note

*Get your vehicle certified by the Government authorised emission testing stations at specified intervals.*

## VEHICLE IDENTIFICATION NUMBER

Serial numbers of both frame and engine are required for vehicle identification. They are also required to assist your Dealer for operating parts or referring to special information.

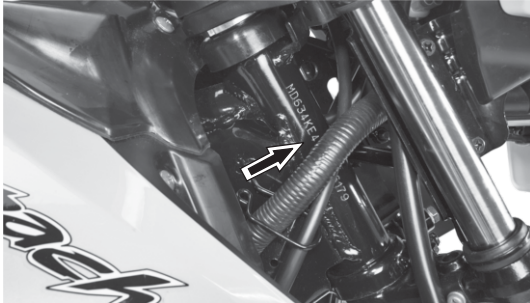

The frame serial number is stamped on the right side of the steering head tube.

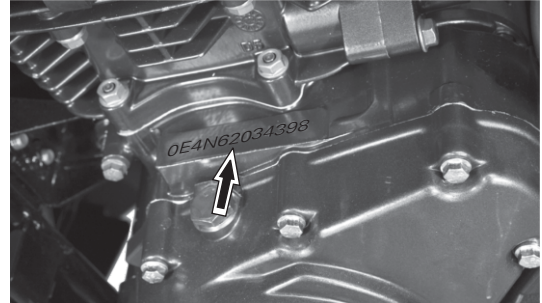

The engine serial number is stamped on the left side crankcase assembly near cylinder block.

Frame number

--	--	--	--	--	--	--	--	--	--	--	--	--	--	--	--	--	--	--	--	--

Engine number

--	--	--	--	--	--	--	--	--	--	--	--	--	--	--	--	--	--

Control key number

--	--	--	--	--	--	--	--	--	--	--	--	--	--	--	--	--	--	--	--	--

*Please fill the above boxes now for future reference*

LOCATION OF PARTS - HANDLE BAR

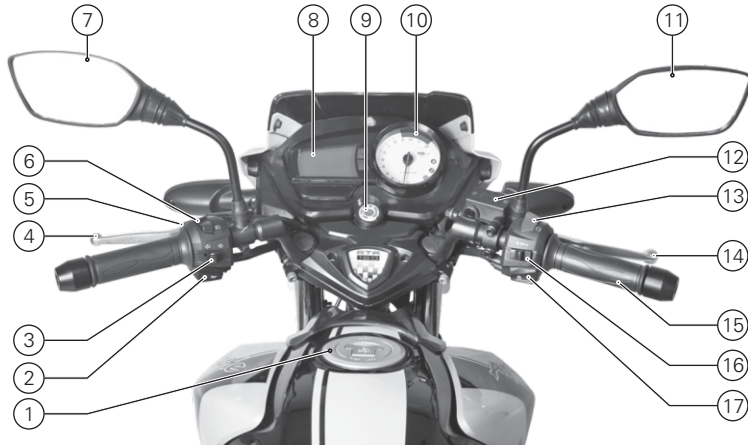

1. Fuel tank cap
2. Horn switch
3. Turn signal lamp switch
4. Clutch lever
5. Pass by switch
6. High / low beam switch
7. Rear view mirror L
8. Digital speedometer
9. Ignition cum steering lock
10. Tachometer
11. Rear view mirror R
12. Master cylinder (front)
13. Engine cut off switch
14. Front brake lever
15. Throttle grip
16. Head lamp switch
17. Electric starter switch

LOCATION OF PARTS - VEHICLE LEFT SIDE

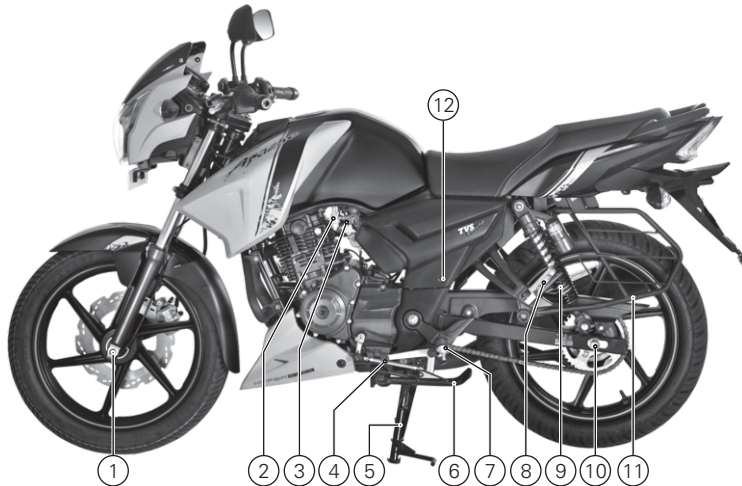

1. Front wheel axle
2. Fuel cock
3. Choke lever
4. Gear shift lever
5. Centre stand
6. Side stand
7. Rider foot rest L
8. Pillion foot rest L
9. Rear shock absorber L
10. Rear wheel axle
11. Saree guard
12. Cover frame L screw

LOCATION OF PARTS - VEHICLE RIGHT SIDE



1. Disc plate front
2. Front wheel axle nut
3. Caliper assembly front
4. Spark plug
5. Gauge oil level
6. Kickstarter lever
7. Rear brake pedal
8. Rider foot rest R
9. Cover frame R lock
10. Pillion foot rest R
11. Rear shock absorber R
12. Rear brake adjusting nut\*
13. Muffler assembly

\* Applicable only for rear drum brake model.



LOCATION OF PARTS - VEHICLE FRONT AND REAR

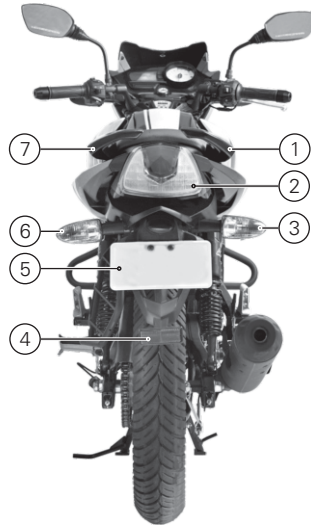
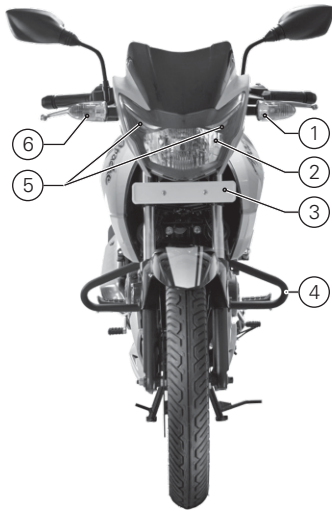

FRONT

1. Turn signal lamp front L
2. Head lamp assembly
3. License plate front\*
4. Crash guard
5. Position lamps
6. Turn signal lamp front R

REAR

1. Pillion handle R
2. Tail lamp assembly
3. Turn signal lamp rear R
4. Reflex reflector
5. License plate rear\*
6. Turn signal lamp rear L
7. Pillion handle L

\* *Mandatory accessory will be charged extra*

### CONTROL KEY

Apache RTR 160 HYPER EDGE comes with a pair of identical control keys. These keys are to operate ignition cum steering lock, fuel tank cap and cover frame R.

### IGNITION CUM STEERING LOCK

There are three positions in the ignition cum steering lock. They are:

#### 1. 'OFF' position

All the electrical circuits are turned 'OFF' in this position. Engine will not start. Key can be taken out.

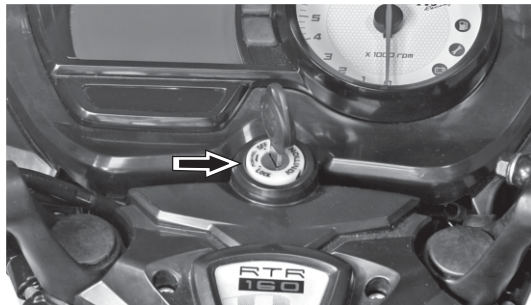

#### 2. 'ON' position

In this position, all the electrical circuits are turned 'ON' and the engine can be started now. Key cannot be removed in this position.

#### 3. 'LOCK' position

Apache RTR 160 HYPER EDGE steering can be locked in both 'left' and 'right' directions.

To lock the steering, turn the handle bar all the way to the 'left' or 'right'. Push the key in and turn it to the 'LOCK' position and take out. All the electrical circuits are turned 'OFF' in this position.

Insert the key into the lock and turn it to 'OFF' or 'ON' position to unlock the steering.

### Note

*Position lamps glows automatically once the ignition key is turned 'ON' without switching on any lamps. When the ignition switch is turned 'ON' the speedometer performs self test (count down starts). Wait till the message 'GO' appears on the speedo dial.*

 Warning

Never attempt to move the vehicle when the steering is locked, you may lose balance.

 Caution

Leaving the ignition cum steering lock in 'ON' position will drain the battery when vehicle is not in use. So "Switch off" and take the key out when the vehicle is unused.

DIGITAL SPEEDOMETER

1. High beam indicator lamp (☰)   
 Glows when the head lamp high beam is activated.
2. Neutral indicator lamp (N)   
 Glows when the vehicle is in neutral and goes 'OFF' if the gear is shifted from neutral.
3. Turn signal indicator lamp (↔)   
 Flashes when the 'left' or 'right' side turn signal indication is activated.
4. Digital clock   
 Displays the time in 12 or 24 hour time format.

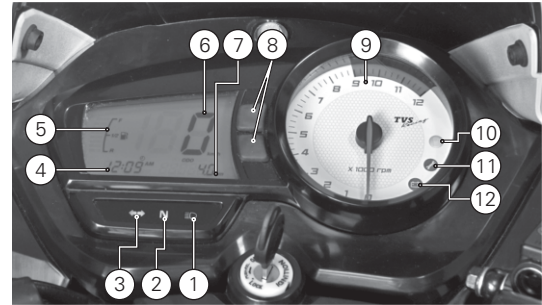

5. Fuel gauge

Fuel gauge indicates the approximate quantity of fuel available in the fuel tank.

6. Speedometer

Indicates the vehicle speed in kilometers per hour.

 Note

If the battery is disconnected and reconnected during service, the clock displays 12:00 by default. You need to reset the time (refer page no. 16).

KNOW YOUR APACHE RTR 160 HYPER EDGE

## 7. Odometer / Trip meter A & B / High speed indicator / Shortest time indicator

Odometer registers and displays the total distance covered by the vehicle in kilometers. The digit after the dot mark denotes one tenth of a kilometer. Set the display in 'ODO' mode to know reading.

Trip meter registers and displays the partial distance covered in kilometers. The digit after the dot mark denotes one tenth of a kilometer. Option is provided to measure two different distances ('TRIP A' and 'TRIP B'). You can reset it whenever required. Set the display in 'TRIP A' or 'TRIP B' mode to know the trip distance.

High speed indicator records the maximum speed (top speed) achieved by the rider so far. You can reset and record new speed if required.

Set the meter in 'HI Spd' mode to know the maximum speed achieved by any user so far.

Shortest time indicator records the minimum time taken so far to reach the 60 kmph speed. You can reset and record new time if required. Set the meter in 'St' mode to know the time consumed by a rider to reach the specific speed from starting.

## 8. Mode and Set switch buttons

To change the mode between 'ODO', 'TRIP A', 'TRIP B', 'HI Spd', 'St' and to set the clock timing, the mode and set switches are provided.

Refer page no. 15 for setting / resetting the odometer, trip meter, high speed indicator and shortest time indicator.



### Note

*Maximum speed recorded so far will be displayed whenever the ignition lock is turned 'ON' and the meter is in 'HI Spd' mode. If the high speed is reset, the speed value will be shown as '0'.*

*Similarly, minimum time taken recorded so far to reach 60 kmph speed will be displayed when the ignition is turned 'ON' and the meter is in 'St' mode. The value will be displayed as 9.9 seconds if the 'St' mode is reset.*

*In 'St' mode, fuel level indication bars of fuel gauge disappears. These bars appears only after changing the mode from 'St' to another.*

### 9. Tachometer

Tachometer indicates the engine speed in multiples of 1000 rpm (revolutions per minute).

### 10. Fuel warning indicator ( )

Fuel warning lamp glows continuously for a few km if the fuel in tank comes to minimum safe level. This gives warning to the rider that the vehicle is running with less fuel and it needs to be filled immediately.

### 11. Service reminder

If the service is due, whenever the ignition switch is turned 'ON', an icon with spanner symbol  blinks for 10 seconds after the self test cycle of speedometer and continues to glow till the vehicle is serviced and reset. Get the vehicle serviced at TVS Motor Company Authorised Distributor / Dealer or Authorised Service Centers.

### 12. Low battery indicator

An icon with battery symbol '  ' glows when the battery charge is too low. Get the battery checked at TVS Motor Company Authorised Distributor / Dealer or Authorised Service Centers.

### Note

*Service reminder indicator lamp works only based on the distance (km) covered by the vehicle. This is only a reminder indicator. Customers are advised to keep track and follow the service schedule.*

### ODOMETER / TRIP METER / HIGH SPEED / SHORTEST TIME INDICATOR SETTING

To change the mode between 'ODO', 'TRIP A', 'TRIP B', 'HI Spd' and 'St' just press the mode switch button 'A'.

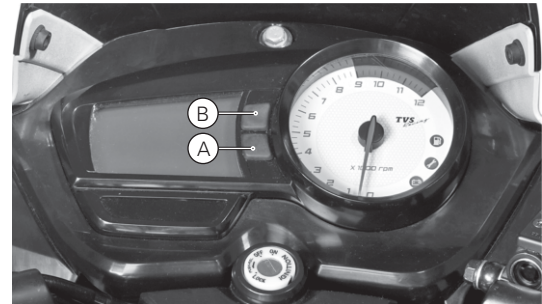

To reset the trip meter / high speed indicator / shortest time indicator, set the meter in respective mode. Press and hold the set switch 'B' for a few seconds.

### DIGITAL CLOCK SETTING

Digital clock can be set in 'ODO' mode only. Set the digital clock time in the following manner:

1. Change the meter to 'ODO' mode by pressing mode switch button.
2. Press and hold the mode switch button (A) for a few seconds to change clock timing to 12 or 24 hour format.
3. Press and hold the set switch button (B) for a few seconds to enter the clock setting mode.
4. Press the mode switch button (A) to increase the hours (while hour digits are blinking).
5. To access the minutes press the set switch button (B) again for few seconds.
6. Press the mode switch button (A) to increase the minutes (while minute digits are blinking).
7. Press the set switch button (B) to exit the setting.

### HANDLE BAR LEFT SIDE

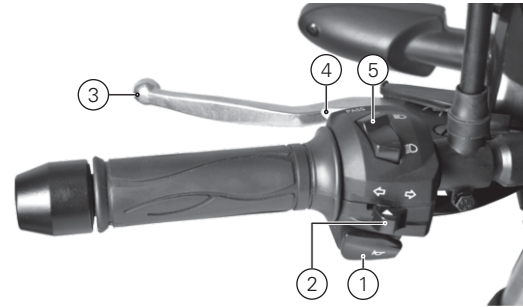

#### 1. Horn switch

Press the switch '📢' to operate the horn.

#### 2. Turn signal lamp switch

Slide the turn signal lamp switch to left '⇐' or right side '⇒' to operate respective turn signal lamps (LH/RH). Press the knob to turn 'OFF'.

#### 3. Clutch lever

Use the clutch lever to disengage the drive to the rear wheel while shifting the gears. Squeezing the lever towards grip disengages the drive.

### 4. Pass by switch

When the pass by switch is pressed intermittently, the head lamp flashes and signals the approaching vehicle. This pass by signal can be used while overtaking other vehicle during day time.

### 5. Head lamp high / low beam switch

With the head lamp switch in 'ON' condition, press the beam control switch towards '☰' to turn-on the head lamp high beam. Press the switch towards '☷' to turn-on the head lamp low beam.

### Warning

*Always use the appropriate turn signal lamps when you intend to change lanes or take turns. Be sure to switch 'OFF' the turn signal lamps after negotiating the turns or lanes.*

*Use appropriate head lamp beam 'high / low' as per the traffic and road conditions for your safety and to avoid inconvenience to other riders.*

## HANDLE BAR RIGHT SIDE

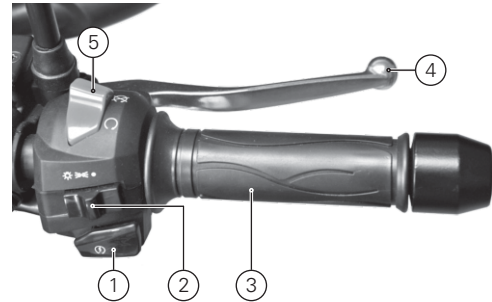

### 1. Electric starter switch

Press the electric starter switch '⚡' to start the engine electrically with the transmission is in neutral or by depressing the clutch lever when the transmission is in gear.

### Note

*For cold starts, avoid using electric starter. Use kickstarter. A typical example is early morning start. This would reduce load on the battery and prevents quick drain.*

## 2. Head lamp switch

Head lamp switch has three positions. Working of head lamp at various positions are as follows:

OFF: All the lamps are turned 'OFF' except position lamp when the switch is positioned at '●' even though the engine is running.

PO: Speedometer back illumination, tail lamp and number plate lamp glows when the switch is positioned at '☰' and engine is running.

ON: Head lamp also glows along with the above said lamps when the switch is positioned at '☀' and engine is running.

## 3. Throttle grip

Engine speed is controlled by the rotation of the throttle grip. Twist it towards you to increase the engine speed and away from you or release it to decrease the engine speed.

## 4. Front brake lever

The front brake is applied by squeezing the front brake lever gently towards the throttle grip. The brake lamp glows on application of front brake.

## 5. Engine cut off switch

To switch off the engine but to keep the battery activated, press the switch to '⊗' position.

To start the engine, press the switch to '⊙' position.



### Note

*Before starting, ensure to turn 'ON' the engine cut off switch.*

*Apache RTR 160 HYPER EDGE is provided with adjustable LH and RH handle bar. Contact your TVS Motor Company Authorised Distributor / Dealer or Authorised Service Centers for any such adjustment.*



### Warning

*Please do not adjust the handle bar your self or by any unauthorised persons. Improper adjustment may affect the maneuverability of the vehicle.*



### FUEL TANK\* CAP

Flush type fuel tank cap (1) is provided in Apache RTR 160 HYPER EDGE. To open the fuel tank cap, lift the protection lid (2), insert the control key into the lock and turn it in clockwise. Take out the tank cap along with the key.

To close, press the cap gently in its position by keeping the front end (↑) towards the handle bar. Take out the key and close the protection lid.

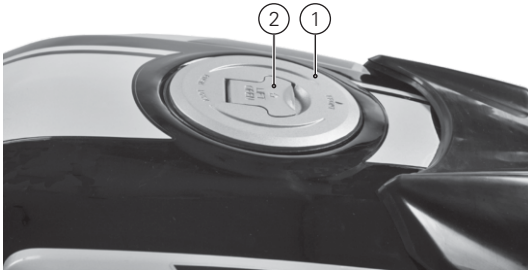

\* The fuel tank is not a measuring instrument and the capacity of the fuel tank may slightly vary from the indicated capacity.

### Warning

*Avoid spilling of fuel on the hot engine. Never refill fuel near open flame. Do not smoke while refueling. Do not use cell phones while refueling.*

### Note

*Whenever refueling the bike, fill upto the bottom of neck portion of the fuel tank. Filling above the neck may result in improper breathing of fuel tank and seepage of fuel.*

### FUEL COCK

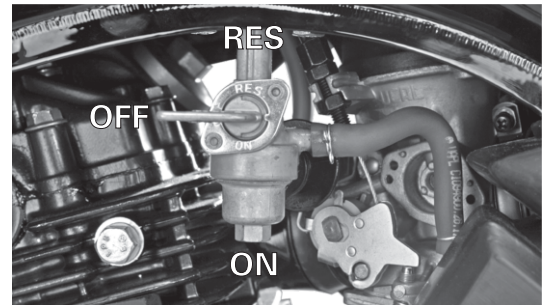

Fuel cock has the following three positions:

- ON: Fuel flows in this position when the fuel is above the reserve level in the tank.
- RES: Switch over the fuel cock lever to this position when the fuel stops flowing in 'ON' position.
- OFF: Fuel flow cuts off from the tank to carburettor.

### Note

*Leaving the fuel cock in 'ON' or 'RESERVE' position may cause the fuel tank to completely drain out, in case any malfunctioning of carburettor float system. Similarly, if the fuel cock is positioned between 'ON' and 'OFF' may drain off entire fuel while riding the vehicle.*

### CHOKE KNOB

Choke 'I/I' is provided in the carburettor assembly itself. Gently pull out choke knob to operate the choke.

**During cold start, apply the choke and start the vehicle using electric starter or kick lever without opening / with less opening of throttle.**

Once the engine is started and running in stable RPM, push back the choke knob and ride the vehicle.

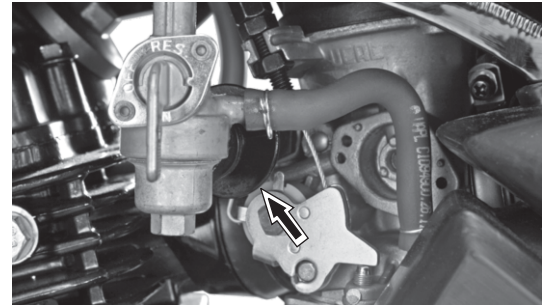

### Caution

*Always use choke for starting the cold engine. Never open the throttle fully when the choke is applied. It may lead to flooding of engine and difficulty in starting.*

### KICK STARTER LEVER

The kick starter lever is located on the right side of the vehicle. To start the vehicle, keep the ignition and engine cut off switch in 'ON' condition. With the transmission in neutral, keep your foot on the lever extension and kick from top and stroke to bottom with rapid motion.



#### Note

*It is recommended to start the vehicle always in neutral gear. However, the vehicle can be started in any gear after depressing the clutch lever.*

### GEAR SHIFT LEVER

Apache RTR 160 HYPER EDGE is equipped with a 5 speed constant mesh transmission. Press the gear shift lever down or lift up with the left foot toe to engage the gears. After selecting a gear, the gear shift lever will return to its normal position, ready to select the next gear.

Each time shifting into the higher gears one by one from neutral position is accomplished by depressing the clutch lever and pressing the gear shift lever (for first gear) or lifting the gear shift lever (for remaining gears) up once for each gear.

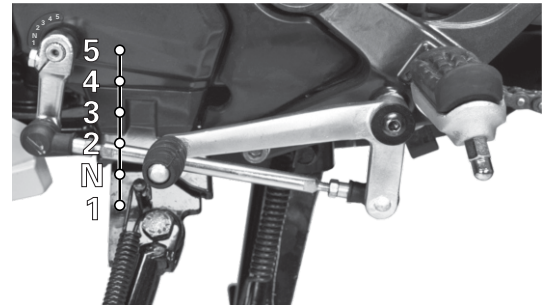

 Note

*Gear shift lever position can be set to your convenience. Contact your TVS Motor Company Authorised Distributor / Dealer or Authorised Service Centers for setting the gear shift lever position.*

REAR BRAKE PEDAL

Rear brake pedal is located on the right side of the vehicle. Press the rear brake pedal with your right foot to apply the rear brake. The brake lamp glows on application of brake.

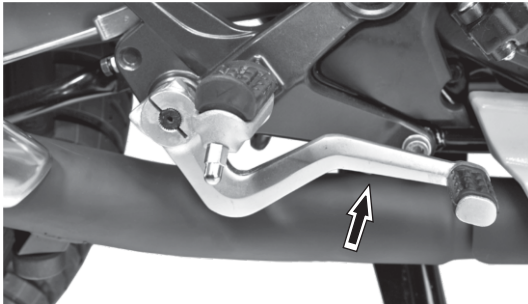

 Note

*Rear brake pedal position can be set to your convenience. Contact your TVS Motor Company AAuthorised Distributor / Dealer or Authorised Service Centers for setting the brake pedal position.*

*After setting the brake pedal position, ensure to check the brake pedal play and adjust as explained in page no. 42 (applicable only for rear drum brake model).*

STANDS

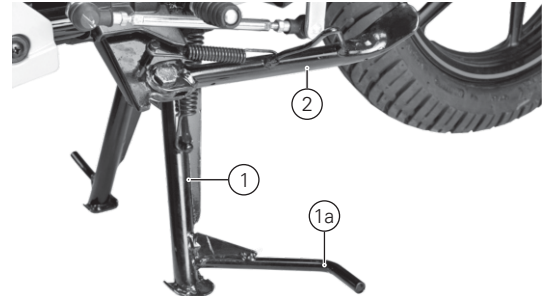

Apache RTR 160 HYPER EDGE is equipped with a centre (1) and side stand (2). To place the vehicle on the centre stand, hold the handle bar left grip with left hand and pillion handle L with right hand.

Place your foot firmly on the centre stand extension (1a) and press with adequate effort. Ensure both the legs of centre stand are touching the ground before placing the vehicle on the stand.

Side stand can be operated by sitting on the vehicle with your left foot by pushing it away from the vehicle till it stops.

### Warning

*Always release the side stand to its full up position before moving the vehicle.*

### Caution

*Never sit on the vehicle when it is supported by side stand. Always park the vehicle on a flat, firm surface.*

## COVER FRAME R

Apache RTR 160 HYPER EDGE is provided with lockable cover frame on the right side for accessing the battery, rear disc brake master cylinder\* and seat lock cable. This cover can be opened in the following manner:

1. Insert the control key in the cover frame lock (1) and rotate it in clock wise direction.
2. Take out the cover frame by gently pulling out at front (2) and rear (3).

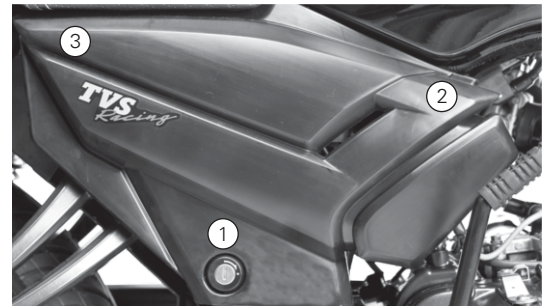

\* Applicable only for rear disc brake model.

Assembling the cover frame back

1. Locate the lugs of the cover frame at (2) & (3) to the hole provided in the fuel tank and frame While ensuring the availability of cushions in the holes
2. Gently press the cover frame lugs into the holes.
3. Now, lock the cover frame by turning the key in anti-clockwise direction.

### TOOL KIT

To assist you in performing certain aspects of periodic maintenance and emergency repairs, a tool kit is supplied along with the vehicle.

A tool kit is located below the seat assembly. To access the tool kit, open the cover frame R as explained earlier and pull the seat lock cable. Carefully take out the seat assembly from its mountings.

Tool kit consists of one number each of the following.

1. Box spanner 16
2. Grip driver
3. Bit (+) (-)

4. 14 x 17 open end spanner
5. 10 x 12 open end spanner
6. Tool bag



### Caution

*It is recommended to use the tool kit in case of any emergency only. It is always advisable to take your vehicle to TVS Motor Company Authorised Distributor / Dealer or Authorised Service Centers.*

### REAR FENDER FLAP

Your Apache RTR 160 HYPER EDGE comes with a removable rear fender flap. Which can be removed or re-fixed for a better look to suit your taste.

Contact nearest TVS Motor Company Authorised Distributor / Dealer or Authorised Service Centers for removing or re-fixing the rear fender flap.

#### Note

*Rear fender, without a fender flap may not protect the mud splashing since it is having the through holes in it. It is strongly advised to fix the flap to protect from the splashing of mud during wet conditions.*

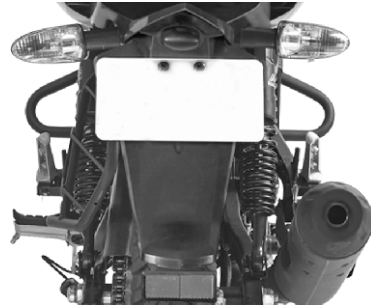

With fender flap

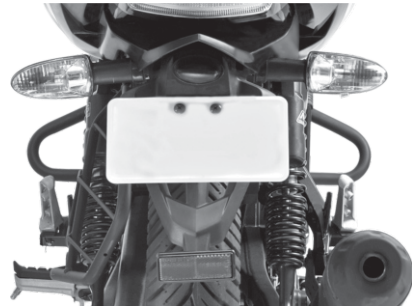

With out fender flap

## INSPECTION BEFORE RIDING

Check the following items before riding.

<b>ITEM</b>	<b>WHAT TO CHECK FOR</b>
Engine cum transmission oil	Availability of oil upto the level (page no. 38)
Fuel	Enough fuel for the planned distance of running
Tyres	Correct pressure (page no. 45) Adequate tread depth / No cracks or cuts.
Battery	Proper working of position lamps, horn, brake lamp, turn signal lamps, neutral lamp, pass by switch and electric starter. Low battery indication (page no. 15) / Electrolyte level (page no. 35)
Speedometer	Performing self check.
Lighting	Proper working of head lamp high beam / low beam, high beam indicator, speedometer back illumination, tail lamp and number plate lamp.
Steering	Smooth movement / No play or looseness.
Throttle	Correct free play of cable / Smooth operation.
Clutch	Correct free play of cable (page no. 38) / Smooth and progressive action
Brakes	Availability of brake fluid, proper working of brake and correct pedal play (incase of rear drum brake) (page no.41).
Wheels	Free rotation



### STARTING THE ENGINE

Turn the fuel cock lever to 'ON' or 'RESERVE' position based on the availability of fuel in the tank. Insert the control key into the ignition cum steering lock and turn it to the 'ON' position. Wait till the self test cycle of speedometer gets over.

Keep the transmission in neutral and press the electric starter switch to start the engine electrically or kick start.

#### When the engine is cold

- ❑ Pull the choke knob and start the engine using kick starter with no opening / very less opening of throttle.
- ❑ Once the engine is started and running stable, push back the choke knob and ride the vehicle (when the engine is warm / hot do not use choke).



#### Warning

*Do not run the engine indoors where little or no ventilation available. Exhaust gas is extremely poisonous.*



#### Caution

*Do not keep the engine in idling rpm for long and do not open excessive throttle when engine is idling and the vehicle is parked. It leads to overheating of engine and damage to the internal components.*

### SETTING THE VEHICLE IN MOTION

1. Depress the clutch lever and engage first gear by pressing the gearshift lever down.
2. Open the throttle slowly and simultaneously release the clutch lever gently and gradually. The vehicle starts moving forward.
3. As the vehicle picks up speed, shift to the next higher gear by closing the throttle, applying the clutch and lifting the gear shift lever up.
4. Release the clutch lever and open the throttle smoothly. Select the required gears in similar manner.

#### Using the transmission

The transmission is provided to keep the engine to run smoothly in its normal operating speed range. The gear ratios have been carefully chosen to meet the characteristics of the engine.

The rider should always select the most suitable gear to achieve the necessary speed and pulling power smoothly.

### Riding on hills / gradients

When climbing steep hills, the motorcycle may begin to slow down and show lack of power. At this point you should shift to a lower gear so that the engine will again be operating in its normal power range. Shift gears rapidly to prevent the motorcycle from losing momentum.

When riding down a hill, the engine may be used as braking by shifting to a lower gear.

### STOPPING AND PARKING

1. Close the throttle completely and apply both the brakes simultaneously.
2. Down shift the gears as the road speed decreases. Bring the engine to neutral position just before the vehicle stops.



### Warning

*Reduce speed to a safe limit before turning / cornering. Do not apply brake while turning / cornering. Do not disengage clutch before braking.*

3. Turn the ignition 'OFF'.
4. Park the vehicle on a firm, flat surface.
5. Lock the steering and turn 'OFF' the fuel cock.

### FUEL RECOMMENDATION

Use unleaded petrol only.

The petrol should be 85 to 95 octane by research method. Use recommended fuel additives for longer life of engine components and lower maintenance. Petrol mixed with ethanol will have impact on engine components. Contact your TVS Motor Company Authorised Distributor / Dealer or Authorised Service Centers for usage.



### Caution

*Never mix oil in petrol in the fuel tank. Always fill fuel from the reputed and reliable fuel stations.*



### Note

*Use fuel additives in petrol as recommended by the respective manufacturer for low carbon deposition.*

### CHECKS AND TIPS FOR IMPROVING FUEL ECONOMY

#### Regular checks

Carry out the periodic maintenance checks as specified in this manual (refer page no. 32 and 33). Regular maintenance checks will save fuel and ensure trouble-free, enjoyable and safe riding besides keeping environment clean.

#### Spark plug

A dirty or defective spark plug leads to wastage of fuel due to incomplete combustion. Inspect and clean the plug if necessary. Visually inspect the spark plug gap and replace if the gap is found more.

**Replace the spark plug every 12000 kms (1 year). Always use recommended spark plug only. Since twin electrode plug is used in the vehicle, do not try to adjust the gap of the electrodes as it may damage the plug.**

#### Air cleaner element

A dirty air cleaner element restricts airflow and increases fuel consumption. **Inspect and clean the air cleaner element periodically. Replace every 12000 kms.**

#### Clutch

Increase in engine rpm during acceleration, without a increase in road speed indicates the clutch slip. A slipping clutch will cause high fuel consumption and engine overheat.

If the condition persists even after adjusting the clutch lever play, immediately have the clutch checked by TVS Motor Company Authorised Distributor / Dealer or Authorised Service Centers.

#### Engine cum transmission oil

Dirty or less engine cum transmission oil increases the friction between various parts of engine and reduces the engine life, thereby increases the fuel consumption.

**Regularly inspect the engine cum transmission oil for correct level and top-up if necessary. Get it replaced at regular intervals as per the maintenance schedule.**



#### Caution

*Never drive the vehicle with half clutch. This will reduce the life of clutch and affects the performance of the vehicle and fuel economy.*

### Fuel leak

Check and arrest fuel leak if any, from tank, carburettor and fuel lines. Loss of fuel due to leak may drain the fuel tank completely.

### Evaporation

Vehicle parked in the hot sun leads to wastage of fuel through evaporation. Also lower fuel levels in the tank will have increased evaporation and condensation of moisture inside, which may result in rusting of the tank.

Ensure to close fuel tank cap after every filling. If the fuel tank cap kept open for long time, it leads to safety and fuel loss.

### Tyres

Low tyre pressure has adverse effects on the vehicle. The **drag on the vehicle** increases resulting decreased fuel economy. Further more, handling may be adversely affected.

Check the tyre pressure regularly (weekly) and inflate it to the recommended pressure (refer page no. 45). Never use tyres which are worn beyond the permissible limit.

### Chain slackness

Check and ensure drive chain slackness. Excess slackness leads to higher fuel consumption (refer page no. 46).

### Wheel freeness

Check and ensure the wheel freeness by rotating the wheel at least once in a week to avoid wastage of fuel.

### Fast starting from rest wastes fuel

A racing start from rest at full throttle can waste fuel and damage the engine. It also creates a potentially dangerous traffic situation.

### Fast acceleration wastes fuel

Fuel is wasted whenever you suddenly accelerate or apply brake.

### Avoid unnecessary idling

While waiting for someone or stopping in signals for long time, if the engine is kept running at idle speed, it causes unnecessary wastage of fuel.

### Avoid frequent braking

Anticipate corners and slopes as well as the traffic conditions. **Unnecessary frequent braking will reduce the fuel economy.**

### MAINTENANCE SCHEDULE

The maintenance schedule indicates the intervals between periodic services. At the end of each interval, be sure to inspect, check, replace, adjust, lubricate and service as instructed. If the maintenance is not done periodically, it will result in rapid wear and severe damage to the vehicle. If the vehicle is used under high stress conditions such as continuous full throttle operation or is used / operated in dusty climate, certain jobs should be performed more often to ensure reliability of the vehicle. Cylinder head, steering components, suspension, chain and wheel components etc., are key items and require very special and careful servicing. TVS Motor Company Limited strongly recommends that the jobs as per the maintenance schedule be performed by your TVS Motor Company Authorised Distributor / Dealer or Authorised Service Centers.

Periodic inspections may reveal one or more parts that may need replacement. Whenever replacing parts on Apache RTR 160 HYPER EDGE, it is recommended that you use only the **TVS Motor Company Genuine** parts.



#### Caution

*Proper running-in and maintenance are mandatory for making certain that your vehicle is reliable and gives optimum performance at all times. Be sure that the periodic maintenance is performed thoroughly in accordance with the instructions given in this owner's manual.*

**PERIODIC MAINTENANCE SCHEDULE (months or km whichever occurs earlier)**

Item	Service km Period from the date of sale	Service						Remarks	
		1st 500-750 1 month	2nd 2500-3000 3 months	3rd 5000-6000 6 months	4th 8500-9000 9 months	5th 11500-12000 12 months	Every 3000 km		Every 6000 km
Engine cum transmission oil		R	R	R	R	R	R	-	
Oil filter (strainer)		C	-	C	-	C	-	C	
Oil filter (paper filter)		R	-	R	-	R	-	R	
Spark plug		I & C	-	-	-	R	-	-	Replace every 12000 km
Air cleaner element <sup>1</sup>		I & C	I & C	I & C	I & C	R	I & C	-	Replace every 12000 km
Carburettor assembly		C & A	-	-	-	C & A	-	-	C & A every 12000 km
Tappet clearance		I & A	-	I & A	-	I & A	-	I & A	
Fuel cock sediment bowl		C	C	C	C	C	C	-	
Hose fuel		I	I	I	I	I	I	-	Replace every three years
All control cables <sup>2</sup>		I, A & L	I, A & L	I, A & L	I, A & L	I, A & L	I, A & L	-	
Throttle grip		-	-	L	-	L	-	L	Lubricate using grease
Choke operation		I	I	I	I	I	I	-	
Steering smooth operation / play		I & A	I & A	I & A	I & A	C, L & A	I & A	-	C & L with fresh grease every 12000 km
Front fork oil		-	-	-	-	-	-	-	Replace every 18000 km
Front and rear suspension		I	I	I	I	I	I	-	Inspect for proper functioning
All fasteners		I & TI	I & TI	I & TI	I & TI	I & TI	I & TI	-	
Drive chain*		C, L & A	C, L & A	C, L & A	C, L & A	C, L & A	C, L & A	-	Adjust if necessary
All bulbs, horn and switches		I	I	I	I	I	I	-	Inspect for proper functioning
Head lamp beam		I & A	I & A	I & A	I & A	I & A	I & A	-	
Battery electrolyte level		I & T	I & T	I & T	I & T	I & T	I & T	-	
Specific gravity and voltage <sup>3</sup>		I	I	I	I	I	I	-	

## MAINTENANCE



Item	Service km Period from the date of sale	Service						Remarks	
		1st 500-750 1 month	2nd 2500-3000 3 months	3rd 5000-6000 6 months	4th 8500-9000 9 months	5th 11500-12000 12 months	Every 3000 km		Every 6000 km
Brake effectiveness		I	I	I	I	I	I	-	
Rear brake pedal play <sup>4</sup>		I & A	I & A	I & A	I & A	I & A	I & A	-	in rear drum brake model
Brake pedal shaft		L	L	L	L	L	L	-	Lubricate using TRU4 oil
Brake pad wear		I	I	I	I	I	I	-	Replace if necessary
Brake fluid		I & T	I & T	I & T	I & T	I & T	I & T	-	Replace every 21000 km
Brake hose		I	I	I	I	I	I	-	Replace every three years
Master cylinder cups		-	-	-	-	-	-	-	Replace every 21000 km
Wheel freeness		I	I	I	I	I	I	-	
Tyre pressure at cold condition		I & S	I & S	I & S	I & S	I & S	I & S	-	
Engine idling RPM		I & S	I & S	I & S	I & S	I & S	I & S	-	
Idling CO% <sup>5</sup>		I & S	-	-	-	-	-	-	
Ball joint gear shift lever		-	-	L	-	L	-	L	Lubricate using grease
Centre / side stand pivot		L	L	L	L	L	L	-	Lubricate using TRU4 oil
Kick starter pedal pivot		L	L	L	L	L	L	-	Lubricate using TRU4 oil
Swing arm bearings		-	-	-	-	-	-	-	Lubricate using grease every two years

R - Replace; I - Inspect; T - Top up; C - Clean; A - Adjust; L - Lubricate; TI - Tighten; S - Set

<sup>1</sup> Inspect for any damage    <sup>2</sup> Inspect for proper operation and adjust play. Lubricate ends using grease.    <sup>3</sup> Recharge if necessary

<sup>4</sup> Clean and lubricate rear brake cam using grease every 6000 km.

<sup>5</sup> Idling CO% should be set with the help of exhaust gas analyser and tachometer only

\* Clean the drive chain with dry cloth and apply TRU SPRAY / TRU4 oil as frequently as every 1000 km for better chain life and smooth vehicle running.

**RECOMMENDED LUBRICANTS**

<b>Application</b>	<b>Qty</b>	<b>Manufacturer</b>	<b>Brand</b>
Engine cum transmission oil	1000 ml (after draining) 1100 ml (after disassembly)	TVS Motor Company	TVS TRU4 PREMIUM, 4T oil
Front fork oil	140 ± 2 ml / leg (Gabriel make) 152 ± 2 ml / leg (Top make)	IOC / Castrol	Teleshockab oil
Disk brake fluid	–	TVS Girling	DOT 3 / DOT 4
Grease	–	Bharath petroleum IOC Bechem	MP Grease no. 3 Servo Gem no. 3 Bechem premium
Chain lubricant	–	TVS Motor Company	TRU SPRAY
Fuel additives	As recommended		IFTEX



## SELF - MAINTENANCE PROCEDURES BATTERY

Battery is located below the cover frame R. The electrolyte level of the battery must be maintained to avoid damages to the battery. To check the electrolyte level, follow the procedure:

1. Place the vehicle on centre stand on a flat surface and open the cover frame R as explained in page no. 23.
2. Inspect the battery electrolyte level. It should be between the upper and lower level.

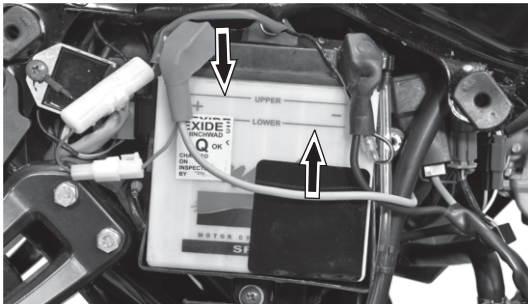

3. If the electrolyte level is below the lower level, add only distilled water upto the upper level by removing the filler caps.
4. Reinstall the filler caps and clean the battery thoroughly, apply petroleum jelly to the battery terminals to protect it from corrosion.

Incase of any abnormality or for removal of battery from the vehicle, contact TVS Motor Company Authorised Distributor / Dealer or Authorised Service Centers.



### Caution

*Once the battery is charged initially, never add diluted sulphuric acid. Use only distilled water for topping up. Never add tap water.*

*Never check the battery charge by shorting the terminals. Always connect the positive terminal first and then negative to avoid sparking.*

*Do not obstruct, bend or change the routing of battery air vent tube. Make sure that the vent tube is firmly attached to the battery and the other end is open and clear.*

### FUSE REPLACEMENT

Non-working of electrical systems may be due to safety fuse failure. Short circuit or overload in the electrical system are the main causes for fuse failure. Follow the procedure given below for inspecting and replacing the fuse.

1. Open the cover frame R as explained earlier (refer page no. 23).
2. The fuse case fitted on the battery band contains a 10A fuse.
3. Pull out the fuse case from battery band.

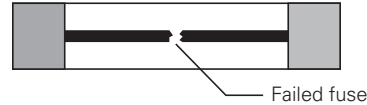
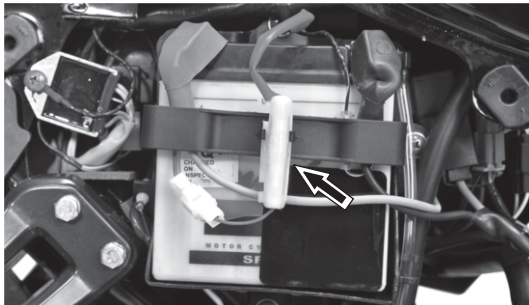

4. Open the fuse case and slide out blown fuse.
5. Replace the fuse with a new (extra fuse is provided inside the fuse case itself).
6. Close the fuse case and re-fix it into the battery band.
7. Turn 'ON' the ignition lock and check for proper functioning of electrical systems. In case the fuse fails again, consult the nearest TVS Motor Company Authorised Distributor / Dealer or Authorised Service Centers.

#### Caution

*Do not use vehicle by shorting the wires without a fuse. This may result in overheating of electrical / wiring and may result in fire.*

*Do not use fuse of higher amperage than specified for the safety of electrical system.*

## SPARK PLUG

1. Clean the dust and mud around the spark plug mounting to avoid falling inside the cylinder.
2. Pullout the suppressor cap from spark plug. Using spark plug spanner, remove the spark plug.

A spark plug with heavy carbon deposits will not produce strong sparks. Hence, only if necessary, remove the carbon deposits from the spark plug with a small wire brush or using spark plug cleaning tool.

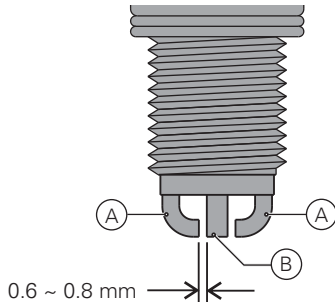

Inspect the spark plug electrodes (A) and (B) for any corrosion. If found any replace the spark plug with a new.

Visually inspect the gap of spark plug electrodes. No manual adjustments of gap is recommended. If the gap found more than specified limit, replace the spark plug.

After cleaning and inspecting the gap, reinstall the spark plug and tighten by hand to avoid cross threading. Finally tighten using the spanner. Do not over tight or cross thread the spark plug .

### Caution

*Always use only recommended make and type of spark plug. Replace spark plug every 12000 km.*

*Cover the spark plug hole with cloth when the plug is removed to prevent dust / water entry.*

*It is advisable to tight the new spark plug by hand till the end and then loose and again re-tight the spark plug by 1/8 of rotation after sealing by using only the hand tool.*

## ENGINE CUM TRANSMISSION OIL LEVEL

Check the engine cum transmission oil level periodically.

1. Place the vehicle on centre stand on a flat surface. Wipe-off the surroundings of gauge oil level.
2. Remove the gauge oil level and wipe it clean.
3. Fix the gauge back to its mounting hole and thread in.
4. Once again remove the gauge and check the oil level.



5. The oil level should be between the minimum and maximum level marks of the gauge as shown in the figure.
6. If the oil level is less than the minimum level, add 'TVS TRU4 PREMIUM' 4T oil upto the maximum level mark.
7. Wipe out the oil traces with a clean cloth to prevent dust accumulation and assemble back the gauge oil level.

### Caution

*If the vehicle is driven with less engine cum transmission oil, engine components will be severely damaged. Check the oil level as per the schedule to avoid costly damage. Do not fill excess oil may cause oil leak. Always use 'TVS TRU4 PREMIUM' 4T oil only.*

## CLUTCH ADJUSTMENT

Clutch lever free play is one of the most important adjustment which you may need to check in-between services for better life of the clutch plates.

The free play of the clutch lever should be 5 ~ 15 mm as measured at the clutch lever end before the clutch begins to disengage.

Adjust the clutch lever free play periodically by means of clutch cable adjuster at arm clutch release if the free play is not within the specified limit.

1. Ensure that the engine is cold.
2. Loosen the lock nut (2) while holding the clutch cable adjuster (3). Adjust the clutch cable adjusting nut (1) 'in' or 'out' to give sufficient play in the clutch lever.

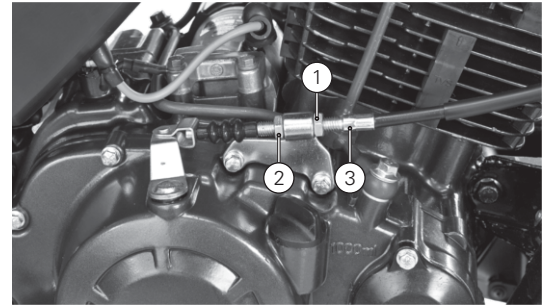

3. After adjusting the play, hold the adjuster nut in the same position, tighten the lock nut.

### Caution

*Too much or too less clutch lever free play will damage the clutch plates, thereby affecting the performance of the vehicle.*

*Clutch lever free play should be adjusted only when the engine is cold.*

## REAR SHOCK ABSORBERS

Apache RTR 160 HYPER EDGE is provided with triple rated, 5 step adjustable, monotube inverted gas filled rear shock absorbers to meet different road and load. There are 5 notches for adjusting spring load.

If the spring is adjusted to the minimum notch, then the shock absorber will be softer which is good for light loads.

If the spring is adjusted to maximum notch, then it will be stiffer which is good for heavy loads.

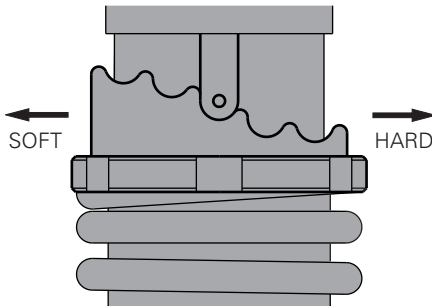

Adjust the spring pre-load by shifting the adjuster to the required notch according to the different load conditions. The more you compress the spring, the suspension becomes more stiff.

### Warning

*Do not heat / tamper the canister filled with GAS.*

### Caution

*Keep both left and right shock absorbers spring adjusters in the same position.*

## BRAKES

### Front brake

You can observe a master cylinder (1) on the right side of the handle bar, a caliper assembly (2) fitted to the fork leg R, a disc (3) to the front wheel and a high pressure hose (4) connecting the master cylinder and the caliper assembly.

1. Check the master cylinder brake fluid level through the viewpiece glass (A).
2. Brake fluid level always should be above the 'LOWER' mark (B) provided on the master cylinder when the master cylinder is parallel to the ground.

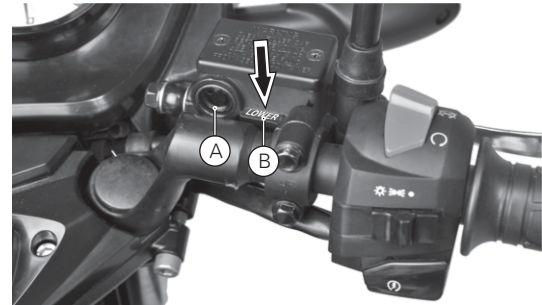
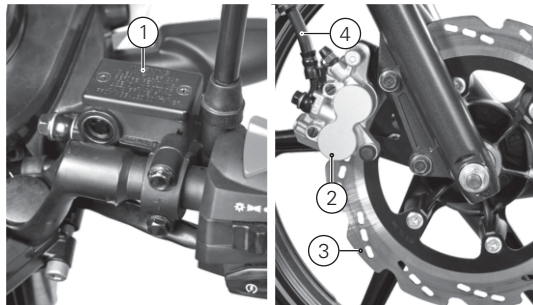

3. If the brake fluid level is below the mark or while applying brake if you feel the brake is more spongy or ineffective due to air entry, contact TVS Motor Company Authorised Distributor / Dealer or Authorised Service Centers for topping-up the brake fluid, air bleeding and other brake related inspections.

### Note

*Check the brake fluid level only when the master cylinder is parallel to the ground.*

### Brake pad wear indicator

Visually check the brake pads wear. If the wear is found beyond the wear indicator groove as shown in the figure then, replace the brake pads as a set with a new one.

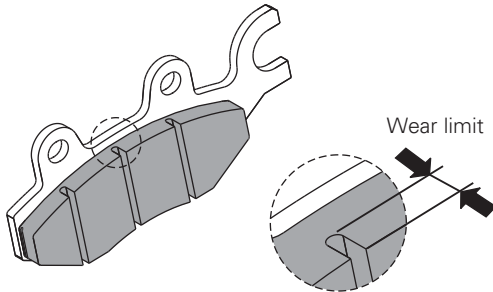

 **Caution**

Replace the brake pads, if the wear indicator shows beyond the wear limit.

### Rear brake (drum brake model)

1. Measure the free play of the rear brake pedal at the pedal end as shown in the figure.
2. The free play of the brake pedal before the engagement of brake should be between 15 ~ 20 mm.

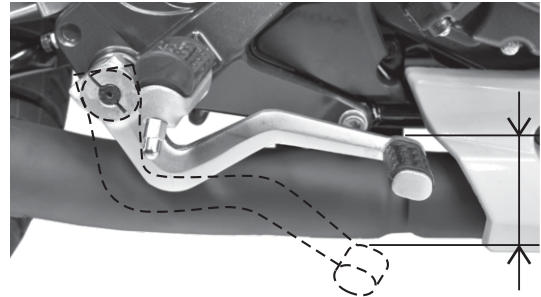

 **Warning**

Check the brake pedal play periodically. However the brake play needs to be adjusted more frequently depending upon the usage.



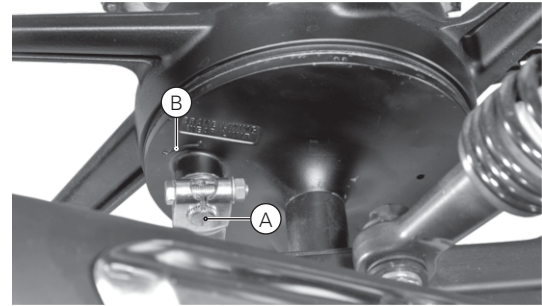
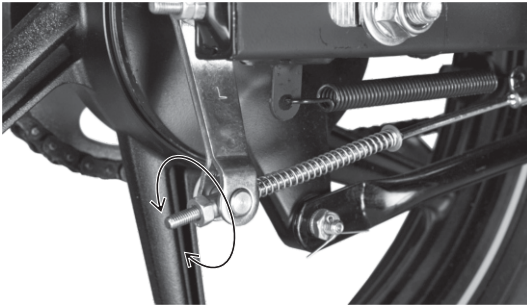

3. If the measured free play is more than the limit, adjust the nut provided at the rear wheel end to obtain the correct play.
4. Turn the adjuster nut clockwise to reduce the free play or turn it in anti-clockwise direction to increase the free play.

### Brake shoe wear indicator

When the brake is applied, the wear index mark (A) on the cam brake should be within the range of wear limit indicator (B) on the rear brake panel assembly.

In case of the mark going beyond the wear limit, index the lever to next slot with the help of Distributor / Dealer to extend shoe life.

### Caution

*Replace the brake shoes as a set, if the wear limit indicator shows beyond the wear limit even after indexing the lever.*

### Rear brake (disc brake model)

You can observe a master cylinder (1) mounted on the right side pillion foot rest, a reservoir (2) below the cover frame R, a caliper assembly (3) fitted on the rear wheel axle, a disc (4) to the rear wheel and a high pressure hose (5) connecting the master cylinder and the caliper assembly.

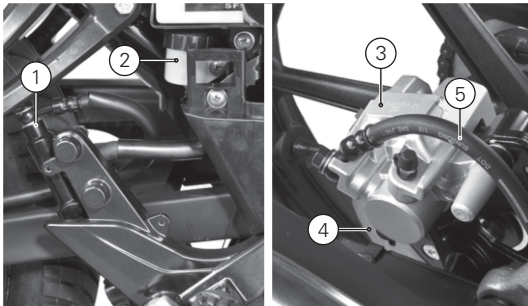

1. Remove the cover frame R (refer page no. 23 for removal procedure).
2. Check the brake fluid level in the reservoir. It should be between maximum and minimum level.

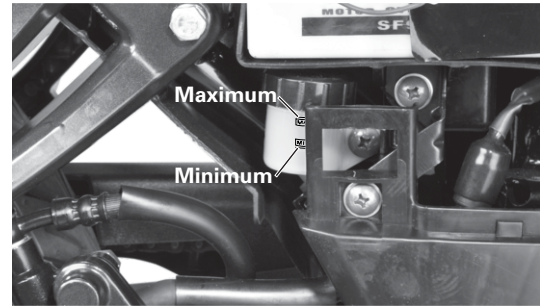

3. If the brake fluid level is below minimum or while applying brake if you feel the brake is more spongy or ineffective due to air entry, contact TVS Motor Company Authorised Distributor / Dealer or Authorised Service Centers for topping-up the brake fluid, air bleeding and other brake related inspections.

Visually inspect the brake pads wear as explained earlier in page no. 42. Replace the pads if the wear is more.

## TYRES

### Tyre pressure:

Check the tyre pressure atleast once in a week if not more frequently. Insufficient air pressure in the tyres not only hasten tyre wear, but also seriously affects the stability of the vehicle.

Under inflated tyres make smooth cornering difficult and over inflated tyres decreases the tyre contact with the ground which can lead to skidding and loss of control. Be sure that the tyre pressure is within the specified limits at all times.

	Solo	Pillion
Front	1.75 kg/cm <sup>2</sup> (25 PSI)	1.75 kg/cm <sup>2</sup> (25 PSI)
Rear	2.00 kg/cm <sup>2</sup> (28 PSI)	2.25 kg/cm <sup>2</sup> (32 PSI)

### Tyre tread condition

Operating the vehicle with excessively worn tyres will decrease riding stability and can lead to loss of control.

It is recommended to replace the tyre when the tyre wears off to the tyre wear indicator level (indicated by TWI on the tyre).



### Tyre rotation direction

While reassembling the tyre, after removing from wheel rim, ensure that the arrow mark (A) provided on the tyre facing the direction of wheel rotation.

### Warning

*The tyre inflation pressure in cold condition and the tyre tread condition are extremely important for the performance and safety of the rider. Check the tyres frequently for inflation pressure as well as the wear pattern on it. Use of a tyre other than the standard may cause instability.*

### Tyre puncture

Apache RTR 160 HYPER EDGE is fitted with a tubeless tyre on both front and rear wheel. In case of any puncture / tyre damage it is advised to visit nearest tyre Distributor / Dealer or the tyre repair shops who know the repairing methods of tubeless tyre.

It is not necessary to remove the tyre from wheel rim always to attend the puncture. Even though, if there is a need of tyre removal, it is strongly recommended to use a tyre removal / fitment machine. If at all, tyre levers need to be used, the levers should be free from sharp edges and care should be taken not to damage the rim and tyre.



### Caution

*Side walls of the tubeless tyres which in contact with the wheel rim are only seals the air inside the wheel assembly. Hence care should be taken not to damage the side walls of the tyres during removal / reassembly.*

### DRIVE CHAIN

Proper lubrication and adjustment of drive chain gives long service life of chain. Poor maintenance of chain causes premature wear or damage to the drive chain and sprockets. The drive chain must be cleaned, checked, lubricated and adjusted at specified intervals mentioned in the maintenance schedule. **Even though the chain is cleaned, lubricated and adjusted during regular service by the Dealers, the user must clean the chain with dry cloth and apply TRU SPRAY / TRU4 oil as frequently as every 1000 km for better chain life and smooth vehicle running.**

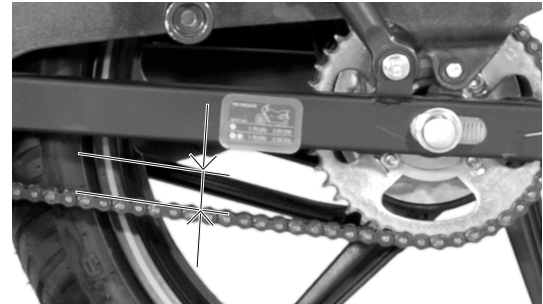

## MAINTENANCE



Check, clean, lubricate and adjust the drive chain in the following manner:

1. Place the vehicle on centre stand with the transmission in neutral.
2. Inspect the drive chain slackness (vertical movement) using the finger as shown in the figure.
3. The slackness of the drive chain should not exceed the limit (20 ~ 25 mm).
4. If the slackness is found more, contact TVS Motor Company Authorised Distributor / Dealer or Authorised Service Centers for adjustment.
5. If the slackness is found within the limit, clean the chain with a dry cloth and lubricate using TRU SPRAY / TRU4 oil.

## FRONT WHEEL REMOVAL AND REASSEMBLY

1. Remove axle nut (1) along with a washer.
2. Pull out the axle (2) along with a washer and take out the spacer from the right side of the wheel.
3. Place a support below the frame to prevent vehicle from falling and lift the vehicle up.

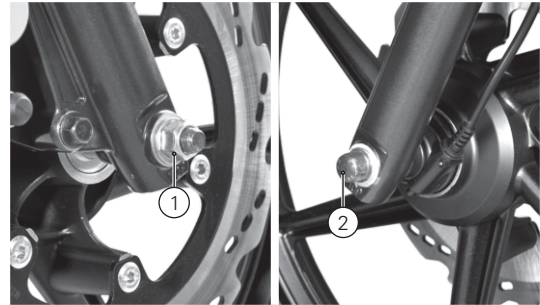

4. Carefully dislocate the disc from the caliper assembly. Dislocate the hub drive from the wheel and slide the wheel out.
5. Reverse the procedure for reassembling. Ensure proper seating of hub drive in the wheel assembly and front fork during reassembly.



### Warning

*Ensure proper seating of disc in the caliper assembly while reassembling.*

## REAR WHEEL REMOVAL AND REASSEMBLY

### Drum brake model

1. Remove the rear brake adjuster nut (1) and disconnect the brake rod.
2. Remove the split pin (2) and the nut (3) from the torque link mounting with the brake panel and disconnect the torque link.
3. Remove the axle nut (4).
4. Pull out the axle (5) and take out the spacer bush from the rear wheel assembly.

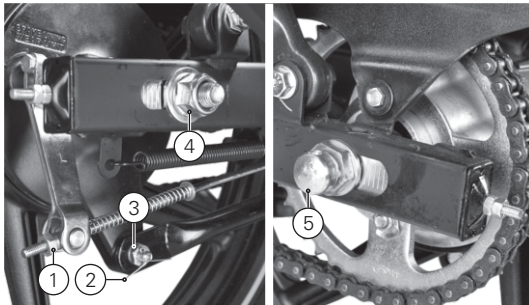

5. Tilt the vehicle to the left and take out the wheel assembly along with the brake panel. Separate the brake panel from the wheel.
6. For locating and reassembling the rear wheel easily, engage the gear. This will arrest the free movement of the drum sprocket. Reverse the procedure for reassembly.



### Caution

*Once the split pins are removed, replace them with new ones.*

### Disc brake model

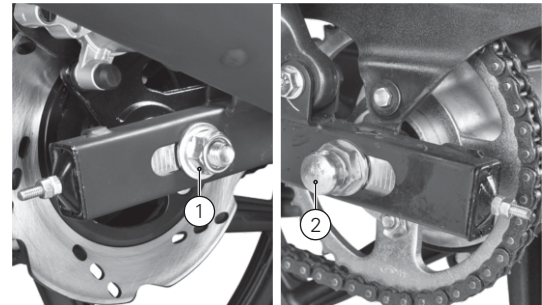

1. Remove the axle nut (1) and along with the washer.
2. Partially pull out the axle (2).
3. Take out the caliper assembly by dislocating it from the disc and the swing arm lug.
4. Carefully hang the caliper assembly in the swing arm itself. Take out the spacer and pull out the axle fully.
5. Remove the wheel assembly by gently tapping it along with the disc.
6. For locating and reassembling the rear wheel easily, engage gear. This will arrest the free movement of the drum sprocket. Reverse the procedure for reassembly.

### Warning

*While assembling the caliper assembly ensure that the slot provided in the caliper is properly located to the lug provided in the swingarm assembly.*

*Always make sure that whenever the wheel is removed, axle nut is properly retightened to the specified torque.*

## STORAGE PROCEDURES

For storage of your motorcycle for longer periods of over a month and above, we recommend to carry out the following steps:

1. Clean the vehicle thoroughly. Park the vehicle on centre stand.
2. Warm up the engine and drain engine cum transmission oil. Store the oil, if new, in a dust free container.



### Warning

*The exhaust system becomes hot after a run. Park the vehicle in a place where pedestrians or children are not likely to touch the vehicle.*



### Caution

*Do not park the vehicle on a slope or soft ground or else it may fall.*

*During storage, the battery must be recharged on a constant current battery charger at recommended amperage atleast once in a month.*

## MAINTENANCE



3. Empty the fuel tank. Turn the fuel cock lever to 'OFF' position.
4. Drain the petrol from carburettor.
5. Remove the spark plug and feed in several drops of engine cum transmission oil through spark plug hole. Crank the engine few times and reinstall the spark plug.
6. Remove the battery, store it away from direct sunlight and freezing temperatures.
7. Place a suitable support at the bottom of the frame so that both the tyres are off the ground. This will ensure better tyre life.
8. Cover up the vehicle completely with a clean tarpaulin or any other suitable cover. Store the vehicle inside a garage or similar area to avoid damage due to dust and rain. Make sure that the storage area is well ventilated and free from any source of flame or spark.

## TAKING THE VEHICLE OUT OF STORAGE FOR REGULAR USE

1. Take the vehicle out of the garage and clean it thoroughly.
2. Remount the battery after bench charging if required.
3. Fill the engine cum transmission oil (TVS TRU4 PREMIUM, 4T oil) and check the oil level using gauge oil level.
4. Lubricate the parts as instructed in the periodic maintenance schedule.
5. Fill up fresh petrol in the fuel tank.
6. Check and inflate the tyres to the specified tyre pressure.
7. Check and correct the points mentioned in page no. 26.



### Caution

*Avoid using alkaline solution like detergent soaps for washing. This may damage head lamp and other lamp assemblies.*



8. Turn the ignition switch to 'ON' position. Start the engine with choke 'ON' for a few minutes and ride out.

### RECOMMENDED TIPS WHEN TAKING A LONG TRIP OF MORE THAN 500 KM:

- A) Please keep the following items for use in case of emergency:
  1. Tool kit complete.
  2. Recommended spark plug one number.
  3. Head lamp and turn signal lamp bulb one each.
  4. Throttle and clutch cable each one each.
  5. Drive chain lock - one number.
  6. First aid kit.
- B) Precautions to be taken for the journey:
  1. Ensure engine cum transmission oil and brake oil level are up to the level.
  2. Adequate fuel in fuel tank.
- C) Check your motorcycle for the following:
  1. Tightness of all bolts and nuts with correct torque value.
  2. Fitness of tyres / tyre pressure / tread depth.

3. All bulbs, indicators and horn function.
4. Smooth functioning of all cables and their free plays.
5. Smoothness of steering operation.
6. Drive chain and sprocket condition. Chain adjustment.
7. Front / rear brake functioning and rear brake lamp switch adjustment.
8. Front fork for any abnormality.
9. Fuel cock bowl filter cleanliness.
10. Spark plug gap and condition of spark plug.
11. Air filter element cleanliness.
12. Correct idling speed.
13. Lubrication of all items mentioned in the periodic maintenance schedule.
14. Any other job as necessary.
15. Have your vehicle checked at any TVS Motor Company Authorised Distributor / Dealer or Authorised Service Centers.



### Caution

*Long journey are to be taken only after the running-in period of 1000 km.*

## SERVICE RECORD SHEET

Sl.No.	Description	Odometer reading	Job card no. / Date	Servicing Dealer's stamp and sign.
1	<b>1st service</b> between (a) <b>500 - 750 km</b> or (b) <b>1 month</b> from the date of purchase, whichever of the two occurs earlier.			
2	<b>2nd service</b> between (a) <b>2500 - 3000 km</b> or (b) <b>3 months</b> from the date of purchase, whichever of the two occurs earlier.			
3	<b>3rd service</b> between (a) <b>5000 - 6000 km</b> or (b) <b>6 months</b> from the date of purchase, whichever of the two occurs earlier.			
4	<b>4th service</b> between (a) <b>8500 - 9000 km</b> or (b) <b>9 months</b> from the date of purchase, whichever of the two occurs earlier.			
5	<b>5th service</b> between (a) <b>11500 - 12000 km</b> or (b) <b>12 months</b> from the date of purchase, whichever of the two occurs earlier.			
6	<b>6th service</b> between (a) <b>14500 - 15000 km</b> or (b) <b>15 months</b> from the date of purchase, whichever of the two occurs earlier.			

**SERVICE RECORD SHEET**

Sl.No.	Description	Odometer reading	Job card no. / Date	Servicing Dealer's stamp and sign.
7	<b>7th service</b> between (a) <b>17500 - 18000 km</b> or (b) <b>18 months</b> from the date of purchase, whichever of the two occurs earlier.			
8	<b>8th service</b> between (a) <b>20500 - 21000 km</b> or (b) <b>21 months</b> from the date of purchase, whichever of the two occurs earlier.			
9	<b>9th service</b> between (a) <b>23500 - 24000 km</b> or (b) <b>24 months</b> from the date of purchase, whichever of the two occurs earlier.			
10	<b>10th service</b> between (a) <b>26500 - 27000 km</b> or (b) <b>27 months</b> from the date of purchase, whichever of the two occurs earlier.			
11	<b>11th service</b> between (a) <b>29500 - 30000 km</b> or (b) <b>30 months</b> from the date of purchase, whichever of the two occurs earlier.			

## TECHNICAL SPECIFICATIONS



**MANUFACTURER** : TVS MOTOR COMPANY LIMITED  
P.B. No1, Bythahalli, Kadakola post, Mysore - 571 311, India.

### ENGINE

Type : 4 stroke, air cooled, single cylinder OHC  
Cylinder bore : 62 mm  
Stroke : 52.9 mm  
Piston displacement : 159.7 cc  
Compression ratio : 9.5 : 1  
Carburettor : Ucal BS-26  
Air filter : Double polyurethane foam filter element  
Oil filter : Wire mesh and micronic paper filter  
Lubrication system : Forced wet sump  
Maximum power in kW : 11.19 (15.2 bhp) @ 8500 rpm  
Maximum torque in Nm : 13.1 @ 6000 rpm  
Maximum speed : 118 km/hr  
Engine idling rpm\* : 1400 ± 100 rpm  
Starting system : Electric starter /kick starter

### TRANSMISSION

Clutch : Wet - Multi plate type  
Gear shift pattern : 1 down and 4 up  
Primary transmission : Helical gears  
Secondary transmission : Chain and sprockets

### GEAR RATIOS

I gear : 2.917  
II gear : 1.857  
III gear : 1.333  
IV gear : 1.050  
V gear : 0.880  
Primary reduction : 3.095  
Final reduction : 3.385

\* Under warm condition

## TECHNICAL SPECIFICATIONS



### CHASSIS

Overall length	: 2085 mm
Overall width	: 730 mm
Overall height	: 1105 mm
Seat height	: 790 mm
Ground clearance	: 165 mm
Wheel base	: 1300 mm
Kerb weight (with toolkit and 90% of fuel)	: 137 kg
Pay load	: 130 kg
Maximum laden weight	: 267 kg
Steering angle	: 36°
Caster angle	: 25.5°
Frame	: Double cradle Synchro STIFF
Front suspension	: Telescopic oil damped
Rear suspension	: Monotube inverted gas filled 5 step adjustable shocks with rectangular swing arm.
Trail length	: 81.3 mm
Turning radius	: 2250 mm

### TYRE

Tyre size	
Front	: 90/90 x 17 (Tubeless)
Rear	: 110/80 x 17 (Tubeless)
Tyre pressure	
Front	: 1.75 kg/cm <sup>2</sup> (25 PSI)
Rear - solo	: 2.00 kg/cm <sup>2</sup> (28 PSI)
Rear - dual	: 2.25 kg/cm <sup>2</sup> (32 PSI)

### BRAKES

Front	: Hand operated, 270 mm petal disc
Rear	: Foot operated, 130 mm dia. (drum brake model) : Foot operated, 200 mm petal disc (disc brake model)

### ELECTRICAL

Type	: AC generator
Ignition system	: IDI - Dual mode digital ignition
Spark plug	: BOSCH UR5DDC - TWIN ELECTRODE
Battery type	: 12V, 9.0 Ah
Generator	: Fly wheel magneto, 12V, 100W
Head lamp	: Halogen HS 12V, 35/35W x 1

## TECHNICAL SPECIFICATIONS



Position lamp	: LED 12V, 3W
Tail/brake lamp	: LED indicators (0.5W / 3.5W)
Turn signal lamp	: 12V, 10W x 4
Number plate lamp	: 12V, 4W x 1
Instrument panel	: LCD / LED indicators
Horn	: 12VDC x 2
Fuse	: 12V 10A x 1

### CAPACITIES

Fuel tank capacity	: 16.0 litres (including reserve)**
Reserve	: 2.5 litres
Engine cum transmission oil grade	: TVS TRU4 PREMIUM, 4T oil
Engine cum transmission oil and capacity	: 1000 ml (after draining) 1100 ml (after disassembly)
Front fork oil grade	: IOC telescopic oil
Front fork oil capacity	: 140 ± 2 ml per leg (Gabriel make) 152 ± 2 ml per leg (Top make)
Brake fluid	: TVS Girling DOT 3 / DOT 4



### Caution

*Using the bulb other than the specified rating can result in overloading of the electrical system or premature failure of the bulb.*



### Note

*Specifications are subject to change without notice.*

\*\* *The fuel tank is not a measuring instrument and the capacity of fuel tank may slightly vary from the indicated capacity.*