



TVS

Jupiter

ZYADA KA FAYDA

USER MANUAL



SCAN FOR 24X7
ROADSIDE ASSISTANCE NOW

WE GO THE DISTANCE WHEN IT COMES TO YOUR ASSISTANCE.

MAKE YOUR RIDES HASSLE-FREE AND STRESS-FREE
WITH SERVICE BEYOND JUST ASSISTANCE.

Sign up for our 24X7 Roadside Assistance and enjoy
quick and efficient service anytime, anywhere.





Drive In.

Drive Out.



**Say bye-bye to waiting time
for servicing your bike.**

Get your vehicle serviced in 1 hour at no additional cost. Contact your nearest Dealership for details.†

† Facility available at selected Dealerships only. Terms and conditions apply





Busy Life? Easy Servicing!

Now, service your bike anywhere, anytime.

- ★ Service the vehicle at your door step.
- ★ Available for regular maintenance or breakdown service only.
- ★ Offered at nominal convenience charges.

Contact your nearest Dealership for details.[†]

[†]Facility available at selected Dealerships only. Terms and conditions apply





Busy Life? Easy Servicing!

Now, service your bike anywhere, anytime.

- ★ Service the vehicle at your door step.
- ★ Available for regular maintenance or breakdown service only.
- ★ Offered at nominal convenience charges.

Contact your nearest Dealership for details.[†]

[†]Facility available at selected Dealerships only. Terms and conditions apply

CONTACT(S) FOR SUPPORT	1
UNIQUE FEATURES OF TVS JUPITER	5
ACCESSORIES	11
FOREWORD	12
NOTICE	13
SAFETY INFORMATION	14
RUNNING-IN INFORMATION	15
SAFE RIDING TIPS	16
KNOW YOUR TVS JUPITER	20
RIDING YOUR TVS JUPITER	76
MAINTENANCE	80
WARRANTY AND SERVICES	105
TECHNICAL SPECIFICATIONS	111
GENERAL INFORMATION	117

**Incase you need any Clarification please contact
TVS Motor Company Authorised Main Dealer / Authorised Dealer**

Or

TVS Motor Company's Area Offices (flip over for addresses)

Or

Toll Free Number : 1800-258-7111

Email : customercare@tvs-motor.com

Disclaimer : TVS Motor Company or any of its officials / Authorized Main dealer / Authorized Dealer do not ask customers for bank / card / wallet details / authentication. In case you face any such claim, please report to the relevant local authorities immediately.

CONTACT AT OUR AREA OFFICES

TAMILNADU-1 & 3

1. TVS Motor Company Limited

V Floor, Gee Gee Universal,
No. 2, MC Nichols Road,
Chetpet, Chennai - 600 031.
Phone : 044-28361651/28361654
Email : AO.Chennai@tvsmotor.com
AO.Madurai@tvsmotor.com

TAMILNADU-2

2. TVS Motor Company Limited

No. 10, 2nd Floor,
Shree Shanmugapriya Towers,
Kannuswamy Street,
Behind Hotel Annapoorna,
R S Puram, Coimbatore - 641 002.
Phone : 0422-4350060/2541035
Email : AO.Coimbatore@tvsmotor.com

KERALA

3. TVS Motor Company Limited

Ambady Towers, Second Floor,
Door No. 27/631, A6,
Edappally-Pookkattupady Road,
Edappally PO., Cochin - 682 024.
Phone : 0484-2544578/2556938
Email : AO.Cochin@tvsmotor.com

KARNATAKA-1 & 2

4. TVS Motor Company Limited

No. 600, Anand Surya, 2nd Floor,
15th Cross, 6th Phase, J P Nagar,
Opp. BMTC Bus Stop,
Bangalore - 560 078.
Phone : 080-26653433
Email : AO.Bangalore@tvsmotor.com

ANDHRAPRADESH & TELANGANA

5. TVS Motor Company Limited

Rukumani Towers, First Floor,
No. 3-11-30, Plot No. 11,
Paigha Colony, Behind Anand Theater,
Secunderabad - 500 003.
Phone : 040-27840590/27844419
Email : AO.Hyderabad@tvsmotor.com

MAHARASHTRA-1 & 2

6. TVS Motor Company Limited

No. 401, 4th Floor, The Chambers,
Plot No. 4/12/3, Near Ganapati Chowk,
Viman Nagar, Pune - 411 014.
Phone : 020-26632112/26632110
Email : Service.pune@tvsmotor.com

MAHARASHTRA - 3

7. TVS Motor Company Limited

No. 502B, 6th Floor, B Wing,
Shriram Shyam Towers,
Near LIC Square, Sardar,
Nagpur - 440 001.
Phone : 0712-2569932
Email : Service.Nagpur@tvsmotor.com

CHATTISGARH

8. TVS Motor Company Limited

Office No. 526, 527 & 528,
Magneto Offizo,
5th Floor, Magneto The Mall,
Labhandi, NH-6, Raipur - 492 001.
Phone : 0771-4260006
Email : AO.Raipur@tvsmotor.com

GUJARAT

9. TVS Motor Company Limited

1208-1213, Shivalik Satyamev,
Below Bopal Over Bridge,
Ambli-SP Ring Road Junction, Bopal,
Ahmedabad- 380 058.
Phone : 079-65443748
Email : AO.Ahmedabad@tvsmotor.com

MADHYA PRADESH-1 & 2**10. TVS Motor Company Limited**

No. 211-212, 2nd Floor,
Chinar Incube Business Centre,
Chinar Fortune City,
Near Brindhavan Dhaba,
Hosangabad Road,
Bhopal - 462 026.
Phone : 0755-2499406/2499306
Email : AO.Bhopal@tvsmotor.com
AO.Indore@tvsmotor.com

RAJASTHAN-1 & 2**11. TVS Motor Company Limited**

Plot No. 17-18,
2nd Floor of National Motors Building,
Jhotwara Industrial Area,
Jaipur - 302 012.
Phone : 0141-5150901/5150902
Email : AO.Jaipur@tvsmotor.com
AO.Udaipur@tvsmotor.com

DELHI & HARYANA**12. TVS Motor Company Limited**

D-3 & D-4, 2nd Floor,
Sector - 10, Noida,
Uttar Pradesh - 201 301.
Phone : 011-29834640/29834773
Email : AO.Delhi@tvsmotor.com

PUNJAB & CHANDIGARH**13. TVS Motor Company Limited**

4th Floor, Royal Business Park,
Chandigarh Ambala Highway,
Zirkapur - 140 603.
Phone : 01762-464777/465777
Email : AO.Chandigarh@tvsmotor.com

UTTAR PRADESH WEST & HILLS**14. TVS Motor Company Limited**

D-3 & D-4, 2nd Floor,
Sector - 10, Noida,
Uttar Pradesh - 201 301.
Phone : 011-29834640/29834773
Email : AO.Delhi@tvsmotor.com

UTTAR PRADESH CENTRAL & EAST**15. TVS Motor Company Limited**

1st Floor, Cyber Tower, TC-34/V-2,
Vibhuti Khand, Gomti Nagar,
Lucknow - 226 010.
Phone : 0522-4918300/4918301
Email : AO.Lucknow@tvsmotor.com

WEST BENGAL**16. TVS Motor Company Limited**

Ground Floor & First Floor,
133 A. S. P. Mukherjee Road,
Opp. Tollygunge Police Station,
Kolkatta - 700 026.
Phone : 033-24617096/24617092
Email : AO.Kolkatta@tvsmotor.com

BIHAR**17. TVS Motor Company Limited**

N-Plaza, Jamal Road,
P. S. Kotwali,
Patna - 800 001.
Phone : 0612-2200068/2200069
Email : AO.BNJ@tvsmotor.com

ORISSA**18. TVS Motor Company Limited**

No. 303, 3rd Floor,
Creative Plaza, Rasulgarh,
Bhubaneshwar - 751 010.
Phone : 0674-2580019
Email : AO.Bhubaneshwar@tvsmotor.com

JHARKHAND

19. TVS Motor Company Limited

Second Floor, Lucas Service Building,
Argora Bypass Road,
Ranchi - 834 002.
Phone : 0651-2244715
Email : AO.Ranchi@tvsmotor.com

NORTH EAST STATES

20. TVS Motor Company Limited

147, Udayan, Ganesh Guri,
Near Hotel D Courtyard,
R G B. Road, Guwahati - 781 005.
Phone : 0361-2202030/2202031
Email : AO.Guwahati@tvsmotor.com

FULLY DIGITAL CONNECTED SPEEDOMETER

The TVS Jupiter is equipped with a 'Fully Digital Connected Speedometer' featuring a reverse LCD display and a range of innovative features, including Bluetooth® connectivity, Real-time indication, Average mileage indication, Time indication, Distance to empty, Digital odometer, Trip meters (A, B, and F), Service reminder, Helmet indication, Economy and Power mode indications, Emergency brake warning, Turn signal lamp reset and Find my vehicle etc. Refer page 27 for more details.

TRIP F : Trip F is a distinctive feature in your vehicle that displays the distance traveled under reserve conditions. This provides vital information to prevent fuel shortages during your journey.



SMARTXONNECT-BLUETOOTH CONNECTIVITY

The connected speedometer of TVS Jupiter comes with built-in Bluetooth® connectivity, allowing you to connect your Android™ smartphone or iPhone® to access features such as caller ID, SMS alerts, Missed call notifications, Voice assist, Navigation and Smart talk directly on the speedometer. Additionally, you can view & share Ride statistics and find the Last parked location of your vehicle & "Find my Vehicle" feature using TVS Connect app to identify your vehicle from a crowded parking lot. Log in to the TVS Connect app to discover more SmartXonnect features.

SMART TALK

The 'Smart talk' feature of your TVS Jupiter communicates crucial vehicle information to you when your mobile is paired with the connected speedometer using mobile app and while using an earphone. Refer page 64 details.

VOICE ASSIST

Another pioneering feature of the TVS Jupiter is its 'Voice Assist' functionality. This feature allows users to control various speedometer functions using voice commands. By connecting to an audio device such as Bluetooth® headphones, users can conveniently control / command the connected speedo via mobile app. Refer page 52 for further details.

FIND MY VEHICLE

Another remarkable feature of your TVS Jupiter is its 'Find My Vehicle' capability. This function enables users to locate their vehicle even after turning 'OFF' the ignition, particularly useful in unfamiliar locations, vast parking areas etc. It operates within a defined distance range between the user and the vehicle and can be conveniently accessed through the mobile app.

'TVS intelliGO'

An intelligent start / stop system that further enhances fuel efficiency. Easy on your pocket and kinder to the environment. Refer page 28 for details.



INTEGRATED GENERATOR (ISG) STARTER

'Integrated Starter Generator' (ISG) system delivers a noiseless start of the vehicle.



iGO ASSIST

iGO assist technology that draws power from Battery for improved Acceleration & Better mileage.

iGO assist improves acceleration and makes it easier to overtake at traffic signals, while enhancing fuel efficiency by an additional 10%. Refer page 47 details.



ECONOMETER®

The TVS Jupiter's speedometer is equipped with a unique feature called 'ECONOMETER'.

This feature is designed to help riders optimize their fuel efficiency by indicating whether they are riding in 'Economy Mode' or 'Power Mode'. Refer page 36 for further details.

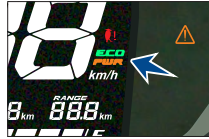

UNIQUE PASS-BY SWITCH

'Pass-by Switch' is a feature allows you to easily switch between high & low beam of the head lamp with easy press and auto release. It is helpful especially while overtaking. Refer page 67 for details.



PREMIUM LED HEADLAMP WITH 'FOLLOW ME HEADLAMP' FEATURE

The TVS Jupiter is equipped with a high-quality 'LED Headlamp', adding premium look to the scooter and provides enhanced brightness making night drive easy and safe.

The 'Follow Me Headlamp' feature of the headlamp extends visibility during nighttime journeys by remaining illuminated for a few seconds even after the ignition is turned off, guiding you safely to your doorstep.



INFINITY LAMPS

The TVS Jupiter is furnished with 'Infinity Lamps', enhancing its appearance with a stylish touch and elevating its overall aesthetic appeal.



TURN SIGNAL CUM HAZARD LAMP SWITCH

'Integrated Turn Signal cum Hazard Lamp Switch' is a feature allows you to operate the turn signal lamp and hazard lamp easily. Refer page 66 for details.



TURN SIGNAL LAMP RESET

The TVS Jupiter includes a unique feature where its turn signal lamps automatically deactivates after 100 meters distance and 20 seconds time. This feature offers riders added convenience, ensuring that the signals are not inadvertently left on, thereby enhancing safety and overall riding experience.

Manual turning-off option is also available for the user to turn OFF the turn signal lamps.

PREMIUM LED TAIL LAMP

The TVS Jupiter is equipped with a premium 'LED Tail Lamp' integrated with turn signal lamps, adding premium look to your vehicle and making night drive easy and safe.



EMERGENCY BRAKE WARNING

Yet another pioneering feature of the TVS Jupiter is its "Emergency Brake Warning" system. When traveling at high speeds, in the event of sudden braking during an emergency event, the system will automatically activate the emergency brake lamps (hazard lamps) to enhance your safety and alert other drivers.

ALL IN ONE LOCK

Your TVS Jupiter has 'All In One Lock' that unlocks the seat and fuel tank cap at the ignition lock itself. Refer page 25 for details.



'TVS intelliGO' SWITCH

An exclusive 'intelliGO Switch' is provided to switch 'OFF' and 'ON' the 'TVS intelliGo' system as and when required. Refer page 68 for details.



RETRACTABLE BAG HOOK

Your TVS Jupiter has a 'Retractable Bag Hooks' to carry light luggage like carry bags weighing upto 3 kg.



FRONT FUEL FILL

Front fuel filling system enables you to hassle free fuel filling without even getting off from the vehicle.



TELESCOPIC FRONT FORK

TVS Jupiter has Motorcycle-like 'Telescopic Front Suspension' for extreme comfort for excellent riding comfort even on bad roads.

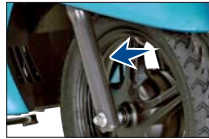

ADJUSTABLE REAR SHOCK ABSORBER

TVS Jupiter comes with 'Adjustable Shock Absorber'. This allows you to adjust the required level of hardness/softness as per the usage requirement at just by rotating the knob.



TUBELESS TYRES

The TVS Jupiter comes with the advantage of 'Tubeless Tyres', which significantly reduces the risk of punctures. Even in the event of a puncture, abrupt air leakage is prevented, enhancing both safety and convenience.



PATENTED E-Z CENTRE STAND

'E-Z Centre Stand' of your TVS Jupiter reduces the effort required to place the scooter on stand. Refer page 70 for operating procedure.



PARKING BRAKE (REAR BRAKE LOCK)

'Parking Brake' is another unique safety feature which protects your TVS Jupiter from falling due to wheel rotation when it is parked with the side stand on a slope. Refer page 67 for details.

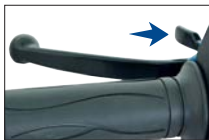

DISC SYNCHRONISED BRAKE TECHNOLOGY (SBT)

Taking technological innovation to next level, your TVS Jupiter comes with 'Synchronised Brake Technology (SBT)'. This feature enhances the safety by avoiding skidding during sudden braking.



ALL BLACK LARGER ALLOY WHEELS

All 'Black Larger Alloy Wheels' with high mechanical advantage gives progressive braking of your TVS Jupiter, results in best-in-class 'shortest distance' braking. It also provide superior comfort in bad road conditions.



UNDER-SEAT STORAGE (UTILITY BOX)

Your TVS Jupiter has a 33 litre under-seat storage space to carry your luggage belongings, two helmet etc. Refer page 72 for further details.

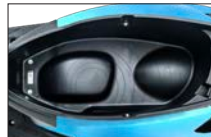

FRONT GLOVE BOX

TVS Jupiter is provided with glove box front. Which has 2 litre storage capacity and used to hold your mobiles while charging or hold a small bottle.



ACCESSORIES FOR YOUR SCOOTER**

SMART PHONE CHARGER

Your TVS Jupiter is provided with a provision for fixing a socket for charging your smart phone even while you are traveling and it is located below the right side of the handle bar near ignition lock. Refer page 74 for usage details.



The following are the list of accessories:

1. Side stand
2. Lady pillion foot rest
3. License plates[#]
4. Kickstarter system in Disc SXC variant
5. Smart phone charger
6. Beeper^{##}
7. Backrest
8. Screen guard for speedometer
9. All round guard
10. Floor mat

*** Optional and Mandatory Accessory will be charged extra*

[#] License plates are mandatory accessory

^{##} Beeper is an optional accessory only in select variant

Welcome to the TVS Jupiter Family!

Congratulations on becoming a proud owner of the all-new TVS Jupiter. Get ready to experience a world of comfort, convenience, safety, style, and performance.

For over 10 years, the TVS Jupiter has been known for “Zyada ka Fayda,” delivering exceptional value to millions. The all-new Jupiter builds on this legacy, offering best-in-class features like Double Helmet Space, Longest seat in its class, Front Fuel Fill, Signature Style Elements, best in class mileage, metal body and much more! It is the perfect blend of style, performance, and utility, designed to make your everyday ride easier, more comfortable, and more enjoyable.

For a complete understanding of your new vehicle’s features and operation, please refer to the owner’s manual. Carefully following the instructions will ensure years of reliable riding. We recommend getting your TVS Jupiter serviced at authorized TVS Motor Company dealerships for optimal performance.

Remember, safe riding is always in your hands. Ride responsibly and enjoy the journey!

TVS MOTOR COMPANY LIMITED

Take time to familiarize yourself with your TVS Jupiter and its performance characteristics.

This Owner's Manual contains a host of useful information. Please take the time to read this manual before you ride your new TVS Jupiter. Get familiarise with the operation of your scooter for maximum safety and pleasure. The better you know your vehicle, the more pleasure you will experience riding your new vehicle. Ensure that anyone else riding your TVS Jupiter does the same.

All information, illustrations, photographs and specifications contained in this owner's manual are based on the latest product information available at the time of this publication. TVS Motor Company Limited may, however, incorporate modifications or improvements on its vehicles at any time without notice, and therefore, in such events it is possible that the relevant part of the owner's manual does not apply to your vehicle. Prior permission of TVS Motor Company Limited is required for quoting, copying or reproducing any part of this owner's manual.

Note

Accessories shown in the picture may not be part of the standard equipment.

Pictures shown in this manual are of TVS Jupiter drum brake model unless specified.

Your TVS Jupiter is provided with always glowing head lamp (AHO). The head lamp glows automatically once the engine is started.

TVS Jupiter is fitted with 'TVS intelliGO' which is an intelligent start/stop system that switches 'OFF / ON' the scooter automatically (refer page 28 for further details).

TVS Jupiter has a side stand sensor, it enables engine cut-off when side stand is in open condition (for anti fall safety). Rider must ensure to close / retract the side stand before starting the vehicle.

Operating this vehicle safely is an important responsibility of the rider. To help you make decisions on safety, we have provided necessary operating procedure and other information in this manual. This information alerts you on potential hazards that could hurt you or others. Since it is not possible to warn you about all the hazards associated with operating or maintaining the vehicle, you must use your own judgment.

You will find important safety information in following form in this manual. These words carry the following connotations:

 **Warning**

*Disregarding this message might result in **injury to the rider or deadly accidents.***

 **Caution**

*This message indicates special procedures or precautions to be followed to **avoid damage to the vehicle.***

 **Note**

*This message provides further clarification for **clear understanding of any particular information.***

The first 1000 km is a crucial part of your scooter. Proper running-in operation during this period helps in ensuring a **maximum life** and **smooth performance** of your TVS Jupiter.

The reliability and performance of your TVS Jupiter depends on the special care and restraint exercised during the running-in period. It is especially important that you avoid operating the engine in high speed (RPM), which could expose the engine parts to excessive stress. Recommended speed during the running-in is:

Maximum 50 km/h speed upto 1000 km (vary the engine speed for better mating of parts).

The first free service at 500 ~ 750 km is most important. During running-in period all the engine components and other parts will have set in. All adjustments to be restored, all fasteners to be tightened. **Engine and Transmission oil to be replaced.** Timely performance of the first free service will ensure optimum service life and performance from the engine.



Caution

Replacing the engine and transmission oil during first service is most important for better life of engine. Always use TVS TRU4 SKUUTA (SAE 10W30 API-SL, JASO MB) oil for better performance and life.

SAFE RIDING RECOMMENDATIONS

Any two wheeler riding requires some precautions to be taken to ensure the safety of the rider, pillion rider and other road users. These precautions are:

Familiarise yourself with new TVS Jupiter

Riding skill and your mechanical knowledge form the foundation of safe riding practices. We suggest you to practice riding TVS Jupiter in a low-traffic condition until you are thoroughly familiar with your vehicle and its controls. Remember practice makes you perfect.

Riding apparel

Loose, fancy clothing can be uncomfortable and unsafe when riding a two-wheeler. Choose good quality two wheeler riding apparel.

Know your limits

Ride within the boundaries of your own skill at all times. Knowing these limits and staying within them will help you avoid accidents.

Warning

Two wheeler safety starts with wearing a good quality helmet. One of the most serious injuries that can happen is a head injury. Always wear an ISI approved helmet that should fit your head comfortably and securely. You should also have good quality goggles to protect your eyes and help your vision.

To prevent or minimize accident, never consume alcohol or drugs before or during the operation of your vehicle. Even minimal consumption of these will affect the rider's ability to control the vehicle.



Posture

Proper vehicle riding starts with proper posture.

1. Keep your elbows relaxed and flexible.
2. Sit and adjust yourself on seat so that arms and shoulders are relaxed.
3. Look widely instead of gazing at one point.

Warning

One-hand riding is dangerous. *Keep both hands firmly on the handle bar and both feet securely on the floor board. Under no circumstances should both the hands be removed from the handle bar, as it is very dangerous.*

Avoid use of mobile phones while riding as it could lead to fatal accident.

Slow down to a safe speed before negotiating a corner. If this is the first time that you are riding a vehicle of this type, we suggest that you practice on a safe, open area to become thoroughly familiar with the operation of the vehicle.

Cornering

When cornering, centrifugal force works in a direction perpendicular to the direction in which the vehicle is moving. Centrifugal force increases in proportion with speed and the radius of the corner.

During cornering, reduce speed so as to lessen the effects of centrifugal force. By all means, avoid abrupt application of brake or sudden steering.

Braking

For safe riding, it is very important to master the braking techniques.

1. Close / release the throttle.
2. Hold the vehicle upright as you apply the brake.
3. Progressive application of brake is safer.
4. Apply both the brakes. 'SBT' provides additional braking even when 'only rear brake' is applied, But applying 'both the brakes' helps you to use the full potential of the brakes.
5. Riding down hills, while cornering and wet roads, close throttle and come to a slower speed to avoid the loss of control over the vehicle due to skidding.

Causes for poor braking

If the brake shoes / pads or drum / disc are worn out or if there is water or oil on them, sufficient friction does not develop and brakes do not work well.

Even when the brake works normally, if the road surface is wet or the tyre surface is worn-out, tyres do not take a firm hold on the surface, increasing the stopping distance.

Approximately 60% braking effect is from front brake.

Non-usage of front brake causes poor braking.

Warning

As the vehicle speed increases, the stopping distance also increases progressively. Be sure that, you have sufficient distance between you and the vehicle or obstruction ahead of you.

*Using only the front or rear brake is dangerous and can cause skidding and loss of control. **Apply both the brakes together and with great care on a wet road or other slippery surfaces.** Any abrupt braking on slippery or irregular roads can cause loss of rider control.*

ACCESSORY INSTALLATION AND SAFETY TIPS

Use extreme caution while selecting and installing the accessories for your TVS Jupiter.

The addition of **unsuitable accessories can lead to unsafe operating conditions.** Your friendly Dealer will assist you in selecting quality accessories and installing them correctly.

While selecting the accessories, make sure that the accessories **should not obstruct lighting, steering, suspension level and ground clearance.**

Additional electrical equipments is not acceptable as it will void warranty terms of the vehicle.

EMISSION CONTROL

All the TVS vehicles are tested in the factory for optimum fuel efficiency and CO levels. If the vehicle needs any adjustments, please consult nearest TVS Motor Company Authorised Main Dealer or Authorised Dealer.

While adequate care is exercised at the factory to ensure that the emissions are within the limits, it is essential for the owner to always maintain the vehicle in good condition by getting it periodically checked and serviced by TVS Motor Company Authorised Main Dealer / Authorised Dealer so that the emission and fuel consumption levels are maintained as per norms.

Crankcase emission control system

The engine of new TVS Jupiter is equipped with a closed crankcase system to prevent discharging crankcase emissions into the atmosphere. Blow-by gas is returned to the combustion chamber through the air cleaner and the fuel system.

Evaporative emission control system

TVS Jupiter is equipped with an evaporative emission control system which consists of a canister and associated piping. This system prevents the escape of fuel vapors from the fuel tank.

Warning

If there is any abnormal jerk, startability issue are felt in the vehicle or noise due to sudden escape of gas during opening of fuel tank cap, immediately report to the TVS Motor Company Authorised Main Dealer / Authorised Dealer.

Note

Your vehicle is tested and certified for emission which meets BS VI emission norms and is valid for initial 12 months from the date of purchase. Get your vehicle certified by the Government authorised emission testing station after initial 12 months of usage. Remember to renew this certification promptly upon its expiry.

VEHICLE IDENTIFICATION NUMBER

The frame and engine serial numbers are the only means of identifying your TVS Jupiter from others of the same model and type. They are also required to assist your Dealer for ordering parts or referring to special information.



The frame serial number is stamped on the frame, at the rear end below the seat assembly. Open the seat assembly to read the frame number.



The engine serial number is stamped on the left side of the engine, at the bottom, near center stand mounting. See bottom to read serial number.



LOCATION OF PARTS - HANDLE BAR



1. Speedometer assembly
2. Rear view mirror R
3. Right hand brake lever
4. Throttle grip
5. 'TVS intelliGO' switch
6. Electric start cum voice assist switch
7. Smartphone charger**
8. All in one lock
9. Glove box
10. Bag hook
11. Fuel tank cap
12. Horn switch
13. Turn signal cum hazard lamp switch
14. Left hand brake lever
15. Parking brake (rear brake lock)
16. Rear view mirror L
17. Beam control cum pass-by switch

*** Optional and Mandatory Accessory will be charged extra*

LOCATION OF PARTS - VEHICLE LEFT SIDE



1. Transmission oil level screw
2. Brake adjuster rear
3. Kickstarter lever**
4. Pillion foot rest L
5. Effortless easy center stand
6. Side stand & side stand sensor***
7. Front wheel axle
8. Brake adjuster front

** Optional and Mandatory Accessory will be charged extra
 *** Kickstarter is accessory in Disc SXC variant

LOCATION OF PARTS - VEHICLE RIGHT SIDE

1. Front wheel axle nut
2. Cover front
3. Pillion foot rest R
4. Gauge oil level
5. Muffler assembly
6. Rear fender
7. Pillion handle
8. Seat assembly



LOCATION OF PARTS - VEHICLE FRONT & REAR



FRONT

1. LED Head lamp
2. Head lamp focus adjuster
3. Infinity lamp cum turn signal indicators front L & R
4. Throttle cable adjuster

REAR

1. Tail / brake lamp cum turn signal indicators rear L & R
2. Number plate lamp
3. Reflex reflector
4. Center stand extension

ALL IN ONE LOCK

TVS Jupiter comes with an 'all in one lock'. It has five positions and they are:

1. 'OFF' position

All the electrical circuits are turned 'OFF' in this position. Engine will not start. Key can be taken out.

2. 'ON' position

In this position, all the electrical circuits are turned 'ON' and the engine can be started now. Key cannot be removed in this position.

3. 'LOCK' position

TVS Jupiter's steering can be locked in both 'left' and 'right' directions.



To lock the steering, turn the handle bar all the way to the 'left' or 'right'. Push the key 'IN', turn it to the 'LOCK' position and take out. All the electrical circuits are turned 'OFF' in this position. **Insert the key into the lock and turn it to 'OFF' or 'ON' position to unlock the steering.**

Note

When you switch on the ignition, the pump priming noise may be heard, which is normal. Avoid frequent 'SWITCH-OFF & ON' of ignition key, to avoid unnecessary run of fuel pump.

Once the ignition key is turned 'ON', the speedometer illumination, tail lamp, and infinity lamp illuminate automatically without activating any other switches.

Caution

Leaving the ignition cum steering lock in 'ON' position will drain the battery when the vehicle is not in use. "Switch Off" and take the key out when the vehicle is not in use. For safety always lock the steering.

Warning

Never attempt to move the vehicle when the steering is locked, you may lose balance.

4. 'Seat unlock' position

The seat lock operation is integrated into the 'all in one lock' of the TVS Jupiter.

To unlock the seat, ensure the key is in the 'OFF' position and then turn key in counterclockwise direction without pushing the key in.

To lock the seat again, push the rear end of the seat back into position. Confirm the seat is locked by listening for a 'Click' sound.



5. 'Fuel tank cap unlock' position

The fuel tank cap lock operation is also inbuilt in 'all in one lock' of TVS Jupiter.

To open the fuel tank cap, ensure the key is in the 'OFF' position, push it in, and then turn it in clockwise direction. The cap will open automatically.

To close the fuel tank cap, press the front end of the cap until you hear a 'Click' sound, indicating it's closed securely.



Note

While closing the fuel tank cap press at the dotted mark area of the cap for easy closing.

FULLY DIGITAL CONNECTED SPEEDOMETER

The fully digital connected speedometer of the TVS Jupiter boasts a wide range of innovative functionalities, complemented by informative tell-tale indicators.

Upon ignition, after self-check, the users are greeted with a welcoming message as illustrated, if your smart phone is not paired with the connected speedometer.

HELLO
RIDER

But if your phone was paired earlier, then the name of the person as stored in the app (if stored) will be displayed instead of 'RIDER'.

Various functionalities and tell-tale information of the meter are explained below in detail.

Note

The name stored in the app has more than 11 characters the connected speedometer scrolls the name from right to left at readable speed.



1. Turn signal indicator lamp left (←)

Flashes when the left side turn signal indication is activated.

2. High beam indicator lamp (≡ ●)

Glowes when the head lamp is activated in high beam or pass-by condition.

3. Malfunction indicator lamp - MIL ()

MIL will be turned 'ON' when the ECU detects a fault in the system and MIL will blink when the ECU detects a misfire in the engine.

If the malfunction indicator lamp '' is glowing continuously or blinking continuously when the engine is started, immediately contact the nearest TVS Motor Company Authorised Main Dealer or Authorised Dealer.

Note

The malfunction indicator will continue to remain switched 'ON' after self checking of connected speedometer until the engine is started. But soon after starting the engine this indicates gets 'OFF' if there is no malfunction is detected in the system.

4. Turn signal indicator lamp right (→)

Flashes when the right side turn signal indication is activated.

5. 'TVS intelliGO' indicator ()

Fuel is consumed unnecessarily when the engine is in idling (eg. in traffic signals) as there is no useful output to the wheel. It contributes to emission and decreases mileage of the vehicle considerably.

To overcome this issue 'TVS intelliGO' system is introduced in TVS Jupiter vehicle to automatically shut down the engine when it is kept idling for long and restart from stop condition by simply pressing the Brake and performing Throttle operation (open and close). **We recommend to use this 'TVS intelliGO' system to improve the fuel economy of your TVS Jupiter and to reduce emission.**

Activation of 'TVS intelliGO' system:

'TVS intelliGO' system gets activated when the following requirements are satisfied,

1. 'TVS intelliGO' switch is in '' position
2. Engine is warmed up and
3. When the vehicle speed has crossed 5 kmph



When the vehicle meets the above conditions, the 'TVS intelliGO' system gets enabled and the intelliGO indicator '  ' in the speedometer glows continuously and informs you that the vehicle has entered into intelliGO mode and the engine will stop automatically at upcoming vehicle idling condition.

Once the vehicle enters the idling condition, the intelliGO indicator starts blinking instead of glowing and the engine stops after predetermined time.

Now, the intelliGO indicator starts glowing again continuously during the engine stop to indicate you that the vehicle has been stopped due to 'intelliGO' system.

The vehicle stopped by 'TVS intelliGO' system can be restarted at any time within 5 min from the stop of the vehicle by intelliGO feature in a simple way of applying the brake and opening & closing the throttle trigger.

Deactivation of 'intelliGO' system:

1. 'TVS intelliGO' system will be deactivated if the intelliGO switch is positioned at '  ' position or if the ISG malfunction indicator '  ' or MIL indicator '  ' is 'ON'.

2. If there is 5 unsuccessful start of the vehicle either by electric start or by intelliGO restart method in one ignition key 'ON' cycle.
3. If vehicle is not restarted within 5 min from idle stop condition.
4. During low battery condition

Prolonged idling:

When vehicle is in idling with the engine temperature high enough to maintain stable engine idling rpm and the intelliGO switch is in '  ' position, then the intelliGO will be activated.

Note

Ensure that the brake free play is adjusted and it is within the limit for the proper working of 'TVS intelliGO'.

Vehicle can be started at any point of time using 'electric start' or 'kick start' when the engine is in stall condition and the ignition key is in 'ON' condition. 'TVS intelliGO' switch can be activated / deactivated at any point of time.

If vehicle is stopped by 'TVS intelliGO' system, and the 'TVS intelliGO' switch is toggled from 'ON' to 'OFF' position and back to 'ON', the intelliGO system will be deactivated and the vehicle can be restarted only by the 'electric start'.

When 'TVS intelliGO' is enabled, the intelliGO lamp glows for 5 seconds and then blinks for predetermined time and then the engine stops. The intelliGO lamp glows continuously once the vehicle has stopped due to intelliGO system.

6. ISG malfunction indicator ()

ISG malfunction indicator will be turned 'ON' when the ISG detects a fault in the system.

If the ISG malfunction indicator is glowing continually after the self check of the speedometer, immediately contact the nearest TVS Motor Company Authorised Dealer or Authorised Dealer.

7. Multifunction display

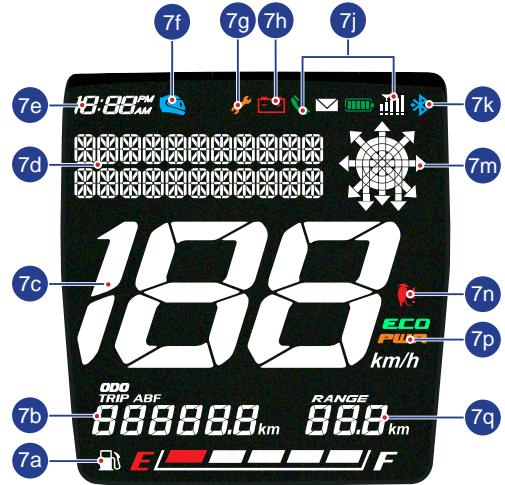

7a. Fuel level indicator (fuel gauge)

Digital bars indicates the approximate quantity of fuel available in fuel tank. There are five bars to indicate the fuel quantity available in the tank. All the five bars will be displayed when the fuel in the tank reaches above 4.35 liters approx.



When the fuel level in the tank reaches 4.1 liters approx the fuel gauge displays only four bars as shown.



When the fuel level in the tank hits approximately 3.1 liters and 2.1 liters, the fuel gauge indicates three bars and two bars respectively, as shown.



Only single bar will be shown when the fuel goes below 1.55 liters approx.



Once the fuel level reaches below reserve level (approx. 1.05 liters) this single segment starts to blink.

Note

Minimum 1.5 liter of fuel should be maintained in the fuel tank to avoid engine switch 'OFF / Damage' to the fuel pump which leads to replacement of pump without warranty.

Fuel level shown is only for reference purpose and users are not encouraged to calculate mileage of the vehicle using the same.

If the side stand is in 'ON' condition, fuel gauge reading will not get updated. The fuel gauge reading gets updated once the side stand is released.

Note

If all the fuel level bars of the connected instrument cluster starts blinking and the below error message is shown in the notification area of the speedometer, contact nearest TVS Motor Company Authorised Main Dealer / Authorised Dealer.

CHECK
FUEL SENSOR

7b. ODO, TRIP A, TRIP B & TRIP F

ODO

Odometer registers the total distance covered by the vehicle in kilometer. The digit after the dot mark denotes one tenth of a kilometer.

ODO

930.2 km

TRIP A & TRIP B

Trip meter indicates the trip distance traveled in kilometer. The digit after the dot mark denotes one tenth of a kilometer.

TRIP A

30.9 km

TRIP B

119.3 km

Provision is provided for the users to measure two different distances as per their convenience. Press the mode button once to enter 'TRIP A' and twice to enter 'TRIP B' from 'ODO' mode (Average time mileage). To reset any of the TRIP (A or B), press the 'SET' button for more than 5 seconds while the display is in respective TRIP and the vehicle is in static condition.

TRIP F

TRIP F

10.2 km

This function shows the distance traveled after the fuel in the tank reaches below the reserve level. The display switches automatically to 'TRIP F' once the fuel reaches the reserve value and starts counting from 0.0 km.

If the fuel level remains in reserve level, the reading will be saved even after the ignition 'OFF'.

The 'TRIP F' meter stops counting and gets cleared automatically once the fuel is filled above reserve level. Once 'TRIP F' is cleared, Trip A / B display switches 'ON' automatically.

Please remember that the 'TRIP F' meter cannot be activated or deactivated manually and can't be reset.

On every ignition 'ON', 'TRIP F' meter will get enabled automatically until fuel level raises above 1.5 liters approx. 'TRIP A', 'TRIP B and TRIP F' will still be accessed by short pressing the 'MODE' switch but the display will automatically enter 'TRIP F' after 5 seconds.

 **Note**

If the ODO / TRIP A or B / TRIP F meter (whichever is in display) segments are flashing and a error message as shown below is displayed on the notification area, contact nearest TVS Motor Company Authorised Main Dealer / Authorised Dealer.

CHECK
SPEED SENSOR

7c. Speedometer

Indicates the vehicle speed in kilometers per hour.



7d. Notification area

This is a general purpose notification area where the greeting message, various informations and warnings are displayed.



7e. Digital clock

Indicates the time in 12 hour time format (AM or PM). Refer page 46 for the time setting procedure.



7f. Helmet icon

With every ignition 'ON', helmet icon  blinks for 10 seconds to remind to wear a safety helmet.

7g. Service reminder

If the service is due, whenever the ignition is turned 'ON', an icon with spanner symbol  blinks for 10 seconds after the self-test cycle of connected speedometer and continue to glow till the vehicle is serviced and the reminder is reset. An information message also will be popped-up in the notification area as shown:

SERVICE
DUE

Get the vehicle serviced at TVS Motor Company Authorised Main Dealer / Authorised Dealer.

Note

Service reminder indicator works only based on the distance (km) covered by the vehicle. This is only a reminder indicator. Customers are advised to keep track and follow the service schedule.

7h. Low battery indicator

An icon with battery symbol  glows when the battery charge is too low.

Following error message also will be popped-up in the notification area when the low battery symbol is turned 'ON'.

LOW
BATTERY

Get the battery checked at TVS Motor Company Authorised Main Dealer / Authorised Dealer.

Caution

Start ability of the vehicle using electric start will be difficult when the low battery indication is 'ON'. The 'intelliGO' feature will be disabled.

7j. Smartphone info

'Smart phone info' displays your smart phone's Bluetooth, Battery level, Network providers signal strength, Call alerts and Message alerts when the connected speedometer is connected via Bluetooth.



Once the speedometer is connected with the smart phone, the speedometer displays the signal strength of the network provider '📶', the battery level '🔋', of the smart phone, message '✉️' and the call '📞' alert.

Note

Incase multiple SIM cards are used in the smart phone, by default, SIM 1's network provider's signal strength is shown in the display of connected speedometer.

Signal strength displayed in connected speedometer might vary from the display in smart phone as the former is referred from telephonic standards.

7k. Bluetooth connectivity (📶)

The connected speedometer of your TVS Jupiter will display the Bluetooth icon (📶) once it is connected with your smart phone through mobile app.

7m. Navigation window (pictogram)

Once the navigation assist is turned 'ON', your TVS Jupiter's connected speedometer displays "Navigation assist ON" and enters into navigation window and displays the turn by turn navigation instruction with a simple and elegant graphical representation.



Note

Please remember that the Navigation License has to be renewed after 5 years of vehicle purchase and renewal can be done by contacting nearest Dealer.

7n. Side stand indicator ()

The side stand warning indicator turns 'ON' to alert you whenever the vehicle's side stand is deployed (vehicle in parked condition).

Note

If the side stand is deployed the vehicle will not start. Retract the side stand to start the vehicle.

When there is a failure in the side stand sensor, in stand deployed condition the vehicle will not stop. As a safety measure it is recommended to visit the nearest TVS Motor Company Authorised Main Dealer / Authorised Dealer to get it rectified.

7p. Economy & power mode indicators ' ' '

Eco indicator (green lamp) indicates that the vehicle is running in economy mode which gives better fuel economy.

Power indicator (amber lamp) indicates that the vehicle is running in power mode which results in reduced fuel economy.

Note

Always ride the vehicle in 'economy mode' for better fuel efficiency.

7q. Range indicator (distance to empty)

Indicates the approximate distance that can be covered by the vehicle with the available fuel in the tank to help you to know when you need to refuel, preventing situation where you might run out of fuel unexpectedly.

To reset the Range indicator, press the 'SET' button for more than 5 seconds. This action resets both 'Range' and 'Average time mileage' readings.

RANGE
15.1 km

Note

Range value will not indicate at full tank and will indicate "--" at low fuel conditions.

9. Mode and Set switch

'MODE' switch is used to change the mode between 'Average mileage & ODO meter, Average mileage & 'TRIP A' / 'TRIP B' / 'TRIP F', 'Real time mileage & ODO meter', 'BLE MODE', 'BRIGHTNESS SET' and 'SET CLOCK' mode.

'SET' switch is used to set the digital clock timing and to erase stored values in various mode.

Sequence of 'MODE' switch are as follows:

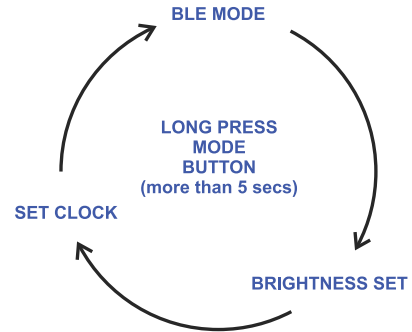
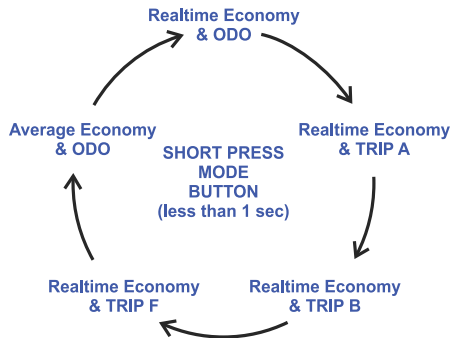

Average economy:

The 'Average economy' option indicates the approximate average fuel economy of the vehicle since the 'Average economy' indicator is reset.

Press the 'SET' button for more than 5 seconds. This action resets both 'Average economy' and 'Range' readings.

AVG ECONOMY
65 Km/l

TRIP A & B:

Trip meter indicates the trip distance traveled in kilometer. Refer page 32 for details.

Resetting TRIP A and B:

Press the 'MODE' switch once or twice to change the display to 'TRIP A' or 'TRIP B' mode which needs to be reset. Now press the 'SET' switch for 5 seconds to reset the respective TRIP data.

Real time economy:

The 'Real time economy' indicates the current fuel economy of the vehicle at that very moment. It displays the real-time fuel economy of the vehicle for the past few seconds when the vehicle is moving at a certain speed.

This will help you to improve your driving pattern and make your vehicle more fuel efficient.

REAL TIME ECONOMY
60 Km/l

BLE mode:

This mode can be entered by pressing 'MODE' switch for more than 5 seconds from any mode.

BLE MODE

When this 'BLE MODE' is activated, the Bluetooth ID of your TVS Jupiter's connected speedometer, scrolls in the notification area's top row. This ID begins with TVSBT followed by a series of alphanumeric characters, as illustrated below.

Example:

TVSBT10052406

The connected speedometer of your TVS Jupiter can be connected to your Android™ smart phone and iPhone® via Bluetooth® through a TVS CONNECT app which can be downloaded from Google Play store and the App store®. Refer page 48 for further details.



TVS CONNECT

First time Bluetooth pairing:

To pair your Android smart phone or iPhone with your TVS Jupiter's connected speedometer, via Bluetooth, for the first time, follow the procedure described below:

1. Switch 'ON' the vehicle.
2. Enter the 'BLE MODE' of connected speedometer as explained earlier.
3. Open the 'TVS CONNECT' app and press the 'CONNECT' icon, while ensuring that the smart phone is near to the vehicle.
4. The app searches for all Bluetooth devices near by and displays the list of devices available.
5. The connected speedometer's Bluetooth ID scrolls at the top row of the notification area. Ex : 'TVSBT10052406'.
6. Now, select the 'TVSBT10052406' in app to initiate the pairing process.
7. On pairing, the connected speedometer displays 'CONNECTION SUCCESSFUL' message for 3 secs and a Bluetooth icon '📶' will be displayed continuously until the pairing condition exits.

CONNECTION
SUCCESSFUL

In Addition to this icon, phone's battery icon '🔋' and signal strength icon '📶' will be also displayed on connected speedometer.

Note

Once the smart phone is successfully paired with the connected speedometer, the digital clock of the speedometer syncs with the smart phone's time and gets adjusted automatically.

Similarly, the rider's name stored in the app will get transfered to speedometer and displayed whenever the ignition is turned 'ON'.

8. If the Bluetooth connection gets disconnected, then the connected speedometer displays the message 'RIDER DISCONNECTED' and the Bluetooth icon disappear instantly.

RIDER
DISCONNECTED

Note

During the course of pairing process, if there is any occurrence of error, the connected speedometer should be turned 'OFF' and 'ON', and the application also need to be restarted.

Please remember that all the smart phones are not compatible for pairing with the TVS Jupiter's connected speedometer.

During the search of Bluetooth devices in app, if the vehicle's connected speedometer's Bluetooth device ID is not visible, try for one or two more iterations.

Any number of Android smart phones can be auto-paired with the connected speedometer of TVS Jupiter, but only one at any point of time will be actively connected with the speedometer.

Only one iPhone can be auto-paired with a single connected speedometer at a time. If the user need to connect multiple iPhones with the single speedometer, the previous connected iPhone has to be forgotten by clicking, 'Forget This Device' from Bluetooth settings of the iPhone.

If the vehicle battery is reset or fuse is blown, then 'Forget This Device' from Bluetooth settings.

Steps to 'Forget This Device' in iPhone:

If the user needs to connect multiple iPhones with the single connected speedometer, the previous iPhone has to be forgotten using 'Forget This Device' from Bluetooth settings in the following manner:

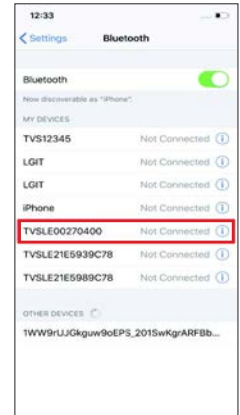
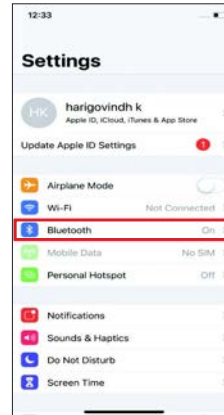

1. In the previous connected iPhone, open the SETTINGS -> BLUETOOTH tab.
2. Select the connected speedometer, which was connected previously.
3. Click on the 'Forget This Device' tab.

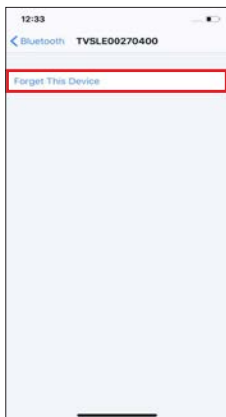

Steps to 'unpair' in Android phones:

Similarly, if the user has any issue in auto pairing the existing paired Android smart phone or to connect multiple Android smart phones with the single instrument cluster, the previous paired Android smart phone has to be unpaired. To unpair an already paired smart phone:

1. In the previous connected Android smart phone, open the SETTINGS -> BLUETOOTH tab.

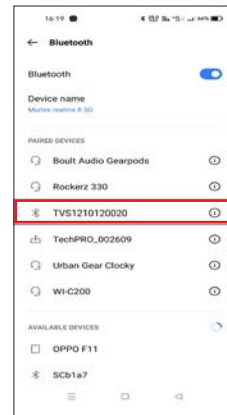
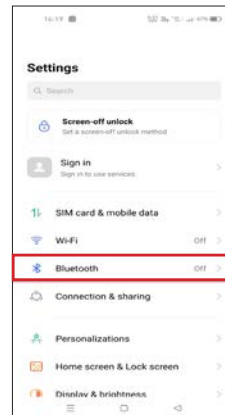

2. Select the speedometer which was connected previously and click on the 'Unpair' tab.



Note

Incase multiple SIM cards are used in smart phone, by default, SIM 1's network provider's signal strength is shown in the display of connected speedometer.

Signal strength displayed in the connected speedometer might vary from the display in smart phone as the former is referred from telephonic standards.

Note

If the smart phone enters battery saver mode, auto-pairing might not happen. It takes maximum of five minutes for auto-pairing and it can happen in vehicle running or engine at idling or engine off condition.

Auto-pairing happens only if the application is locked in the RAM in multitasking screen of the smart phone which has customized OS (Ex : MI, Vivo etc.).

In case of Android smart phones with Android OS version above 8.0, for App to work seamlessly, any battery optimization setting to be removed in the TVS Connect App and GPS shall be allowed to run in background in high accuracy mode.

Even if your smart phone's Bluetooth is already paired to other gadgets like smart watch, health band or helmet, the auto-pairing works with your TVS Jupiter's connected speedometer.

If the application unfortunately stops due to unforeseen circumstances, close and reopen the application and do the manual pairing for the first time, then auto pairing will happen subsequently.

For first time pairing, logout from the app, login again with your login credential and press 'CONNECT' tab.

Auto pairing:

Once the first time pairing is done between vehicle's connected speedometer and your smart phone, the smart phone will automatically connect with the vehicle when the following conditions are met:

1. Vehicle is switched 'ON' and vehicle is near to the smart phone.
2. Smart phone's Bluetooth is turned 'ON'.
3. First time pairing is ensured.
4. In case of iPhone, the 'TVS CONNECT' app should be opened or be opened in background for auto-pairing to happen.

Every time auto-pairing happens, app will open automatically and connect with the connected speedometer. The connected speedometer displays 'CONNECTION SUCCESSFUL' message at the notification area.

CONNECTION
SUCCESSFUL

Once the connected speedometer of your TVS Jupiter is connected with your smart phone, the connected speedometer displays Bluetooth '❄️' icon, your smart phone's battery level '🔋' icon and network providers signal strength '📶' icon.

If your smart phone is disconnected from the vehicle's connected speedometer then, 'RIDER DISCONNECTED' message will be displayed on the connected speedometer's display.

RIDER
DISCONNECTED

Incoming call alert display '📞':

After pairing, the connected speedometer will display the incoming call alerts from the smart phone via Bluetooth. Ex. 'CALL FROM TVSM', will be displayed if the contact is stored in the smart phone otherwise number will be displayed. Ex. 'CALL FROM 9999999999'.

CALL FROM
TVSM

CALL FROM
9999999999

Incase if the incoming call is missed, the number of missed calls will be displayed as shown below for 10 seconds.

01
MISSED CALL

The last caller details incase if the caller ID is stored in the memory will be displayed as shown below:

CALLER NAME
TVSM

Incoming SMS alert display '✉':

The connected speedometer's TFT will display the incoming SMS alerts from the smart phone via Bluetooth. Ex. 'SMS FROM TVSM', will be displayed only if the contact is stored in the smart phone.

SMS FROM
TVSM

Navigation assist:

After pairing, once the navigation option is enabled on the mobile app, the speedometer enters the navigation mode and displays the below message:

NAVIGATION
ASSIST ON

On receipt of the navigation commands from the mobile app, the same will be indicated by the speedometer to the user using the alpha-numeric display as shown below:

450m
TURN RIGHT 

The route suggested by the app is not followed and alternate route is taken, re-routing will be done by the app and the same will be displayed by connected speedometer as shown:

RE-ROUTING

During navigation, if the 'MODE' button is short pressed, the distance remaining to reach the destination will be displayed by the connected speedometer as shown below:

DISTANCE LEFT
40 Km

Similarly, if the 'MODE' button is short pressed again the estimated time of arrival will be displayed by the connected speedometer as shown below:

TIME LEFT
ETA-10:21AM

Once you reach your desired destination, the connected speedometer displays arrival message as shown below:

YOU ARRIVED

Brightness set:

Press the 'MODE' switch for more than 5 seconds from 'BLE MODE' to enter the 'BRIGHTNESS SET' mode. Now press the 'SET' switch to increase / decrease the display screen brightness percentage.

BRIGHTNESS
SET - 60 %

On each press of the 'SET' switch, the brightness value increases with the increment value of 20% till it reaches the maximum of 100%.

Note

By default, the brightness value is set at 60%. Once the illumination level is altered and after ignition is reset (ON / OFF), the last set value will be saved.

If the clock is set by mode switch operation and if the illumination is set by Bluetooth mobile application,

From 6:00 AM to 6:00 PM illumination shall be 100%.

From 6:00 PM to 6:00 AM illumination shall be 60%.

If clock is not set by mode switch operation or illumination is not set by Bluetooth mobile application, LCD brightness value will be default value 60%.

Phone battery low indication:

If the connected smart phone's battery charge status is lesser than 10% then, the speedometer displays the below warning message:

PHONE LOW
BATTERY

Set clock:

From the 'BRIGHTNESS SET' mode press the 'MODE' switch for 5 seconds to enter 'SET CLOCK' mode.

SET CLOCK

- On entering the 'SET CLOCK' mode, the hour digit of the digital clock starts blinking. Now, press the 'SET' switch to increase the hours.
- Press the 'MODE' switch again until the minute digits of the clock starts blinking.
- Once the minute digits started blinking, press the 'SET' switch to increase the minutes.
- Again press the 'MODE' switch till the AM/PM digit of the clock starts blinking.
- Once the 'AM/PM' digit started blinking, press the 'SET' switch again to swap between 'AM' and 'PM'.
- Long press the 'MODE' switch to exit the clock setting.

Alerts messages

Fuel sensor error message:

If there is any malfunction in the fuel sensor 'CHECK FUEL SENSOR' error in the connected speedometer display. Refer page 32 for details.

Speed sensor error message:

If there is any malfunction in the speedo sensor 'CHECK SPEED SENSOR' error in the connected speedometer display. Refer page 33 for details.

Service reminder:

Service reminder '' turns 'ON' whenever the service is due and till the reminder is reset. Refer page 34 for complete details.

Low battery indicator:

An icon with battery symbol '' glows whenever the battery charge is too low. Refer page 34 for complete details.

High speed alert:

Whenever the you are riding your TVS Jupiter at high speed than set speed, the 'HIGH SPEED ALERT' will be displayed by the connected speedometer as shown below:

HIGH SPEED
ALERT

Note

The default value for high-speed alert is set as 80 kmph. But this value can be customised using TVS CONNECT mobile app and same will be communicated to the connected speedometer once it is paired with the app.

iGO assist indicator:

TVS Jupiter is equipped with lightweight engine with iGO Assist. This feature delivers a boost in acceleration from a standstill and during overtaking scenario. The speedometer displays "  " to indicate the customer

to use assist and the speedometer displays "  " when the feature is active, supporting speeds up to 80 km/h.

This system will be automatically activated when the following conditions are fulfilled:

- The engine temperature exceeds approximately 55°C.
- The vehicle has traveled approximately 100 meters.

TVS CONNECT APP



Dedicated smart phone app is available in the Google Play and the Apple store for your 'TVS Jupiter' and it can be installed in your Android and Apple smart phones. To access the features of your TVS Jupiter's connected speedometer like:

- Incoming call alerts, SMS alerts, number of missed call alerts, last caller information etc. in the connected speedometer.
- Voice assist & smart talk.
- To know the battery status and signal strength of your smart phone in connected speedometer.
- To enable / disable auto reply SMS to the callers via smart phone (applicable only for Android smart phones).
- Fuel status, distance to empty, live tracking (speed & mileage of current ride) details in App.

Note

This App is compatible only for the smart phones with Android OS Kitkat (4.4) and above, iOS version 9 and above and the BLUETOOTH version 4.0 and above. Android and Google Play are trademarks of Google LLC. App Store® and iOS are trademark of Apple.

- To enable / disable 'Do Not Disturb' mode during the ride (applicable only for Android smart phones).
- To enable / disable 'High Speed Alert' during ride.
- To send navigational assist instructions inputs to the connected speedometer from your smart phone.
- To save the last traveled route.
- To locate the last parked location of your TVS Jupiter.
- To generate, store and share Ride reports.
- To sync the connected speedometer clock with smart phone clock.
- To control the background illumination of the connected speedometer.

This dedicated mobile app of your TVS Jupiter can be downloaded from the Google Play store and the App Store® by searching the key word '**TVS CONNECT**' else by scanning the below QR code.



Android



iOS

How to login

On opening the **TVS CONNECT** App the following introductory screen will be displayed.

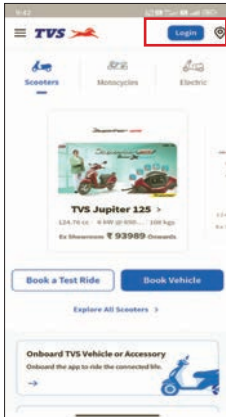

Click on the 'Login' tab provided at the top of the screen to begin a login process.

On entering the login screen you will be prompted for your registered mobile number entry. Enter the mobile number and press 'Continue' tab to proceed further.



Now, an OTP verification screen will get open. Key-in or copy & paste the OTP received from TVSM to login.

Note

During login process, will be prompted for various permissions by the App. Provide necessary permission to the app to work seamlessly.

An logging in successfully the default vehicle screen opens as shown below with various informations.

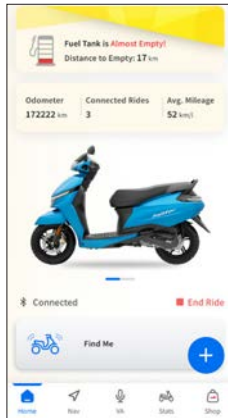

Note

Refer App help for complete details.

Onboarding TVS Vehicle

You can onboard your TVS vehicle into the App by following the procedure given below:

- Scroll down the initial screen and click on the 'Onboard TVS Vehicle or Accessory' tab and select the 'Onboard a TVS Vehicle' option.

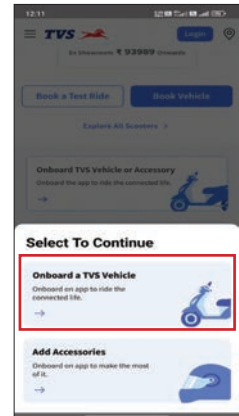
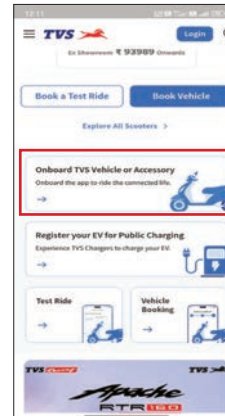

- On selecting this option, a screen with options of adding your vehicle or accessories will get open. Select the 'Add Vehicle by VIN' tab of the screen.
- Now, Another screen gets open with the VIN number and Invoice date or Engine/Motor number entering options.
- Key-in the necessary data to add the required vehicle and press the 'Add' button at the bottom of the screen.

Note

You can get the number by chatting with us or by E-mailing to us or by calling us.

After completing the trip, whenever the vehicle is switched ON again, TVS Connect app will not connect automatically. Click the 'Connect' button of TVS connect app to connect with cluster.

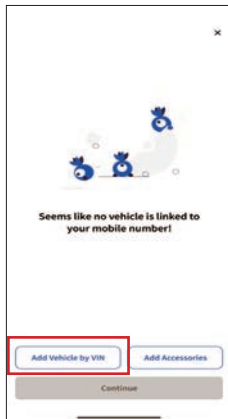

VOICE ASSIST

We have upgraded our electric start switch with an additional function to invoke voice assistant. Once, the mobile app is connected to the connected speedometer.

There are two ways to invoke voice assist in your scooter:

1. By pressing the Electric start / Voice assist switch for >2s.
2. By pressing the voice assist icon in the app live dashboard as shown on the image. This will work irrespective of engine is 'ON/OFF'.

Note

Voice assist will work with screen lock condition / app background condition.

Use wired / wireless headphone for listening and talking. Voice feedback will work only if a wired / wireless headphone is connected. Option to enable / disable voice assistant and voice feedback is available in App settings.

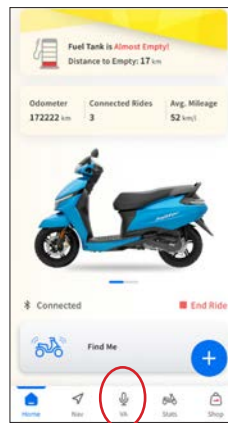

After invoking voice assist through either of the two ways, 'LISTENING' will appear on the screen of the connected speedometer.

This is when we have to start speaking / providing the command.

LISTENING

After listening the voice command, while the command is getting processed, the connected speedometer displays the following information.

PROCESSING

Once the voice assist is activated, when it is not in receiving state, ie. when the call is activated or during other command etc. the connected speedometer displays the information as illustrated below:

PLEASE TRY
AGAIN LATER

At certain circumstances, if the app is unable to process the request or the request is not clear, then the 'RETRY' information will be displayed by the speedometer:

RETRY

Once the voice assist is activated, if you say 'HEY BUDDY', the speedometer display the following message:

HELLO
RIDER

If the you provide a command that is not in the list of command (refer page 64), the message 'REFER TO CMD LIST' will be displayed on the connected speedometer.

REFER TO
CMD LIST

If the Internet is switched 'OFF' or Internet connection is poor and if you try to use some features requiring network connection like navigation, etc., 'PROVIDE DATA ACCESS' message will be displayed in the connected speedometer.

PROVIDE
DATA ACCESS

Note

But if your phone was paired earlier, then the name of the person as stored in the app (if stored) will be displayed instead of 'RIDER'.

The name stored in the app has more than 11 characters the connected speedometer scrolls the name from right to left at readable speed.

The following are the list of intents recognized by voice assist. You can refer page 64 for sample commands of each intent:

- Greeting command
- Navigation command
- Nearest POI command
- Brightness increase / decrease command
- Current location / save location command
- Last call list
- Current time display
- Enable / Disable Auto SMS
- Enable / Disable Do Not Disturb
- Enable / Disable High Speed Alert
- Share Trip details through Whatsapp
- Volume increase / decrease
- Remind me to <do something> at <time>

Note

If you prompt to take to some location or prompt to take to nearest POI after invoking the voice assist, based on the time required to fetch the location, 'PROCESSING' command will be shared by the mobile app and same will be displayed by the connected speedometer and the turn by turn navigation starts afterwards to the desired location or POI.

Once the voice assistant is invoked, if you prompt increase / decrease the brightness of the connected speedometer, then the LCD brightness will be increased / decreased accordingly. Ex. 'BRIGHTNESS INCREASED'

When the speedometer is at maximum brightness or at the minimum brightness, if the brightness increase / decrease command is provided by you, the connected speedometer displays the messages 'MAXIMUM BRIGHTNESS' or 'MINIMUM BRIGHTNESS' respectively.

If you request for your current location after invoking the voice assist, then the location will be fetched and it will be displayed in the cluster as a pop-up Ex. 'ELECTRONIC CITY'. If the time to locate and display the location is greater than 2 secs, then 'PROCESSING' will be displayed.

 **Note**

If you asks for number of missed calls after invoking the voice assist, the number of missed calls will be fetched and the same will be displayed on the screen by the connected speedometer. EX. '01 CALLS MISS'.

 **Warning**

TVS Motor Company Limited does not recommend usage of any type of Mobile Hand Held Devices, and applications / features whether installed or associated with the vehicle which deprives the rider's attention and focus while riding the Two Wheeler. The customers and riders are strictly advised to understand the applicable laws, road safety Rules and the local laws on usage of electronic devices while operating the vehicle. Usage of any Mobile or hand held devices, and / or applications / features while riding the vehicle is on move is totally at customer's / rider's risk. The product and features have technical limitations and are for general overview only.

Voice assist commands and key words

Sl. No.	Intent	Commands	Voice Feedback
1	GREETING	Hi buddie	HELLO " _____ "
		How are you doing	
		Hey buddie	
		Hello friend	
		How u doing	
2	NAVIGATION	Go to	TAKING YOU TO " _____ "
		Take me to	
		Let's go to	
		Navigate to	
		Navigate me to	
		Guide me to	
		Show me	
		Take to	
		Directions to	
		Show me Directions to	

Sl. No.	Intent	Commands	Voice Feedback
3	POI	Near	TAKING YOU TO NEAREST " _____ "
		Near by	
		Near to	
		Nearest	
4	BRIGHTNESS INCREASE	Brightness Increase	BRIGHTNESS INCREASED
		Brightness Up	
		Brightness High	
		Increase the speedo brightness	
		Turn up the brightness	REFER TO CMD LIST
		Turn off night mode	
		Increase the brightness	
		Increase speedo brightness	BRIGHTNESS INCREASED
5	BRIGHTNESS DECREASE	Brightness decreased	BRIGHTNESS DECREASED
		Brightness down	
		Brightness low	
		Reduce the speedo brightness	
		Turn down the brightness	
		Switch the display to night mode	

Sl. No.	Intent	Commands	Voice Feedback
6	BRIGHTNESS DECREASE	Decrease the brightness a bit	REFER TO CMD LIST
		Decrease the speedo brightness	BRIGHTNESS DECREASED
		Decrease speedo brightness	
		Go dark	REFER TO CMD LIST
7	CURRENT LOCATION	My location	LOCATION " _____ "
		Where we right now	
		What is the name of this place	
		Where am i right now & how far we are	
		Where am i now	
		What is my current location	
		Show my location	
		Show my current location	
		Show current location	
		Show location	
Where are we right now			

Sl. No.	Intent	Commands	Voice Feedback
8	CALL MISSED	How many missed calls I have	" ____ " MISSED CALLS
		Have I missed calls	
		Missed call	
		Number of missed calls	
		Did i get any calls	
		Show me missed calls	
		Update status on the missed call	
9	CALL LAST	Last call	CALL FROM " _____ "
		Who called me last	
		Who called recently	
		Last caller	
		Show my last caller	
		Who is my last caller	
10	SPEED	What is my top speed	TOP SPEED " ____ " kmph
		My highest speed	
		What is my last high speed	
		Top speed	
		How fast did i go	
		How fast are we	

Sl. No.	Intent	Commands	Voice Feedback
11	SPEED	Show me the stats for the last ride	TOP SPEED "____" kmph
		Tell me the top speed for the last ride	
		Whats my top speed achieved in my last ride	
		What's the top speed we hit toady	
		Show my highest speed	
		Show top speed	
		Show my top speed	
12	SETTING AUTO SMS ENABLE	Enable auto sms	
		Auto reply SMS ON	
		Auto SMS ON	
		Auto reply ON	
		Enable auto reply	
13	SETTING AUTO SMS DISABLE	Disable auto sms	
		Auto reply SMS OFF	
		Auto SMS OFF	
		Auto reply OFF	
		Disable auto reply	

Sl. No.	Intent	Commands	Voice Feedback
14	SETTING DND ENABLE	Enable do not disturb	ENABLED DND
		Do Not Disturb enable	
		Do Not Disturb ON	
		Enable DND	
		DND setting enabled	
		DND mode enabled	
		Do not disturb setting enabled	
		Do not disturb mode enabled	
15	SETTING DND DISABLE	Disable do not disturb	DISABLED DND
		Do Not Disturb disable	
		Do Not Disturb OFF	
		Cut calls while riding	
		Disable DND	
		DND setting disable	
		DND mode disable	
		Do not disturb setting disable	
Do not disturb mode disable			
16	VOLUME INCREASE	Increase volume	VOLUME INCREASED
		Volume up	
		Increase sound	

Sl. No.	Intent	Commands	Voice Feedback
17	VOLUME DECREASE	Decrease volume	VOLUME DECREASED
		Volume down	
		Decrease sound	
		Reduce volume	
18	SETTING HIGH SPEED ALERT ENABLE	Enable high speed alert	ENABLED SPEED ALERT
19	SETTING HIGH SPEED ALERT DISABLE	Disable high speed alert	DISABLED SPEED ALERT

 **Note**

The list of commands and intent will be updated periodically. Please refer to the command list mentioned in the mobile app to stay updated.

Things to do while using voice assistant:

1. We recommend to use ANC (Active Noise Canceling) Bluetooth devices for better performance.
2. Ensure Microphone is kept near to your mouth while giving out commands.
3. Please ensure that it is not exposed to outside environmental noise such as wind noise, other vehicles' noise etc.
4. We recommend you to go through the sample command list before trying your intent.
5. Kindly refer to the voice feedback of the detected place name when you provide voice command for navigation.
6. Make sure you have the engine running when voice assist is invoked through vehicle switch.

Things not to do while using voice assistant:

1. We recommend you not to use the method of invoking voice assist through mobile App while riding.
2. Please do not use voice assist functionality during heavy traffic condition.

Customization of follow me headlamp timer using TVS Connect app

Follow me home headlamp timer can be customized using the mobile app through the settings screen.

The default timer of 20 seconds can be varied to 10,15, 20, 25 or 30 seconds as per user preference.

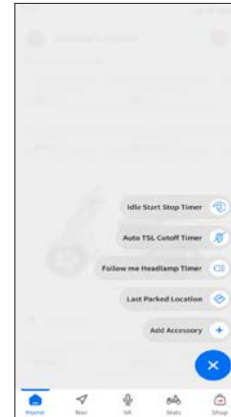

Voice assist commands and key words

TVS Jupiter is equipped with yet another first-in-class feature – Smart talk.

Smart talk feature communicates from vehicle to customer of either critical parameters like fuel level or achievements done like top speed achieved as shown below:

Sl. No.	Smart talk feature
1	Info through audio feedback when App connect / disconnects
2	Fuel wastage
3	Fuel warning
4	Phone low battery warning
5	Voice over on automatic Traffic sequence
6	Rain warning

PREMIUM LED HEADLAMP WITH 'FOLLOW ME HEADLAMP' FEATURE

TVS Jupiter is equipped with a high-quality 'LED Headlamp' which glows automatically once the engine is started. The headlamp beam (low/high) can be controlled by changing the beam control switch position to 'Low' or 'High' beam.

The 'Follow Me Headlamp' feature of the headlamp, extends visibility during nighttime journeys by remaining illuminated for 20 seconds even after switching 'OFF' your vehicle to guide you to reach home safely in darkness.



INFINITY LAMPS

The TVS Jupiter is furnished with 'Infinity Lamps', enhancing its appearance with a stylish touch and elevating its overall aesthetic appeal.





HANDLE BAR LEFT SIDE

1. Horn switch

Press the switch '  ' to operate the horn.

2. Turn signal cum hazard lamp switch

Slide the turn signal cum hazard lamp switch knob to left '  ' or right side '  ' to operate the respective turn signal lamps (LH / RH). Gently press the switch knob to turn 'OFF' the lamps.



Warning

Always use the appropriate turn signal lamps when you intend to change lanes or take turns.

Press the turn signal cum hazard lamp switch knob continuously for few seconds to operate the hazard lamps '  ' whenever it is necessary to park the scooter in a hazardous location due to emergency situation.

This makes all the turn signal lamps to flash simultaneously to make other road users aware of presence of the vehicle. Gently press the switch knob to turn 'OFF' the lamps.

3. Left hand brake lever (SBT brake lever)

Synchronised Braking Technology (SBT) can be operated by pressing the left hand brake lever gently towards the handle grip.

SBT technology helps to operate both front and rear brakes by distributing the force optimally between the two braking system.

Warning

Usage of hazard switch in engine 'OFF' condition can lead to battery drain and can affect the electric startability of the vehicle.

Since your vehicle is fitted with SBT brake system it is essential to maintain the brake system in good condition. Adjust the brakes system at regular intervals for the proper working of SBT.



4. Parking brake (rear brake lock lever)

Brake lock protects your scooter from rolling-off, when parked on side stand (or) helps you relax while waiting in a long traffic signal (or) a slope.

To activate brake lock, press the brake lever almost half towards the grip and hold, then press the parking brake lever to maximum and release the brake lever slowly. Ensure the brake is locked properly. Pressing the brake lever further releases the brake lock automatically.

5. High/low beam cum pass-by switch

The headlamp glows automatically once the engine is started. Only the headlamp beam (high / low) can be controlled by pressing the 'high / low beam' switch.

Press the switch towards '  ' to operate headlamp high beam or press it towards '  ' to operate headlamp low beam.

TVS Jupiter has a combined switch for headlamp 'high / low beam' and 'pass-by' operation. To operate the 'pass-by', keep the switch in 'low beam' position, press gently and release. This makes the headlamp high beam to flash and signal the approaching vehicle. The pass-by signal can be used while overtaking during day time.

Warning

*Ensure release the brake lock before riding the vehicle.
Use appropriate headlamp beam 'high / low' as per the traffic and road conditions for your safety and to avoid inconvenience to other riders. It is strongly recommended to ride the vehicle in 'low beam' during day.*

HANDLE BAR RIGHT SIDE



1. 'TVS IntelliGO' switch

To activate the 'TVS IntelliGO' system, set the IntelliGo switch to ' (A) ' position. The IntelliGo indicator ' (A) ' of the speedometer glows for 2 seconds.

To deactivate 'TVS IntelliGO' system, set the IntelliGo switch to ' (A) ' position.

2. Right hand brake lever

Front brake system can be operated by pressing the right hand brake lever gently towards the throttle grip. The brake lamp glows on application of either right hand or left hand brake lever.

3. Throttle grip

Engine speed is controlled by the rotation of the throttle grip. Twist it towards you to increase the engine speed and twist it away from you or release it to decrease the engine speed.

4. Electric starter cum voice assist switch

Retract the side stand and press the starter switch ' (⚡) ' to start the engine electrically along with the application of either front or rear brake.

Once the vehicle is started (engine is 'ON') the same switch can be used to activate the voice assist ' (🗣️) ': Simple short press the switch to activate the voice control when your smart phone is connected with your connected speedometer.

Caution

It is not recommended to add any additional throttle grip (cover).

Note

Refer page 28 for IntelliGo feature details.

FUEL TANK* CAP

Fuel tank is located at the front end of the vehicle below the handle bar.

To open the fuel tank cap, follow the procedure given in the page 26. To close the cap, gently press the cap in its position and ensure locking by hearing 'Click' sound.



* The fuel tank is not a measuring instrument and the capacity of the fuel tank may slightly vary from the indicated capacity.

Caution

Ensure that the fuel gun is inserted fully into the tank neck while refueling.

Whenever refueling, fill upto the bottom of the neck portion (insert level) of the fuel tank. Filling above the neck may result in improper breathing of fuel tank and seepage of fuel.

While refueling, avoid spillage of petrol on the tyre. If fuel spills on tyre, the tyre will loose its grip on the road. Ensure to close fuel tank cap without fail to avoid fuel spillage.

Warning

Never refill fuel near open flame. Do not smoke while refueling. Do not use cell phones while refueling.

Note

While closing the fuel tank cap press at the dotted mark area of the cap for easy closing.

KICKSTARTER LEVER***

The kick starter lever is located on the left side of the vehicle. To start the vehicle, park the vehicle on center stand and turn 'ON'. Move the lever extension (A) outwards and keep your foot on the lever extension.

Kick the lever from top and stroke to bottom with rapid motion. Push back the lever extension to its original position once the vehicle is started.



Caution

Park the vehicle on center stand before applying the kick starter lever to avoid kick lever hitting with center stand.

*** Kickstarter is accessory in Disc SXC variant

EFFORTLESS E-Z CENTRE STAND

TVS Jupiter is equipped with a effortless center stand. The center stand (1) has a pivoted flexible spring loaded lever arm (stand extension) (2) to increase the lever ratio, which enables parking on center stand effortlessly and very conveniently.

To place the vehicle on center stand, hold the handle bar left grip with left hand. Place your foot firmly on the center stand extension (2) and press.



Caution

Never sit on vehicle when it is supported by stands. Always park the vehicle on a flat, firm surface.

SIDE STAND**

Side stand can be operated by sitting on vehicle with your left foot by pushing it away from the vehicle till it stops.



Note

If the side stand is deployed before starting the vehicle, the vehicle will not get started. And if the side stand is deployed with the engine running condition, the engine gets 'OFF' automatically to ensure the safety.

If there is a error in the side stand sensor the indication will blink and the vehicle will not start. In such condition, please visit the nearest TVS Motor Company Limited Authorised Main Dealer / Authorised Dealer.

*** Optional and Mandatory Accessory will be charged extra*

TOOL KIT AND FIRST AID KIT

To assist you in performing certain aspects of periodic maintenance and emergency repairs, a tool kit is supplied along with the vehicle and it is located below the seat base. To access the tool kit, seat need to be opened. Follow the procedure given in the page 26 for the seat opening procedure.

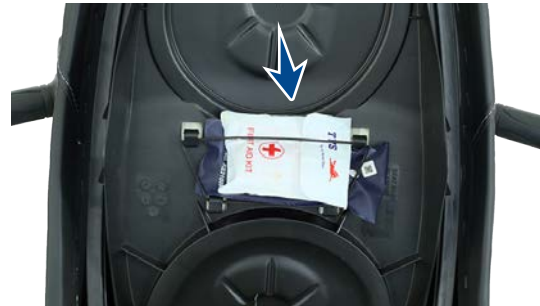

Caution

It is recommended to use the tool kit in case of any emergency only. It is always advisable to take your vehicle to TVS Motor Company Authorised Main Dealer / Authorised Dealer.

The tool kit consists one number each of the following. Ensure the contents of the tool kit.

- 10x12 mm spanner
- Combination screw driver bit
- Screw driver handle
- Tool bag

Warning

Do not remove the tool kit and first aid kit from the vehicle. Always ensure to keep them along with the vehicle. Ensure the first aid equipments are changed periodically based on the date of expiry.

UTILITY BOX

Utility box is located below the seat. Lift the seat by unlocking the seat lock as explained in the page 26 to access the utility box.



Warning

Operating the TVS Jupiter overloaded will hamper the riding stability and may lead to loss of control. Hence, it is advisable to carry the recommended amount of load only.

 **Caution**

Utility box can be used to carry a load of 33 litre maximum.

Do not carry perishable items inside the utility box. It is not fully sealed. Do not allow / spray water to get inside the utility box. Take care not to spill petrol or oil into the utility box.

*Do not keep heat-sensitive items inside as it may get hot on long rides. **Do not keep valuable items inside the utility box when leaving the vehicle unattended.***

GLOVE BOX FRONT

TVS Jupiter is provided with glove box front. Which has 2 liter storage capacity and used to hold your mobiles while charging or hold a small bottle.



 **Warning**

Ensure that your mobile or any material stored is safely held with in the glove box front while riding your TVS Jupiter.

BAG HOOK

A bag hook is provided with your TVS Jupiter to carry light luggage like carry bags weighing upto 3 kg. This hook is located below handle bar on the rear panel.



Just pull out the hook from the top (A) to hang your luggage. Push back the hook once it is free.

Caution

Care should be taken not to attach the luggage which hangs out of your scooter. Please note that the luggage attached to your scooter should not interfere your feet movement.

SMART PHONE CHARGER**

A smart phone charger is provided with your vehicle and it located below left side of the handle bar. This smart phone charging socket enables you to charge your smart phone when you are traveling.

Please go through the operating manual of the mobile phone and use a suitable adaptor for the battery operation recommended by the mobile phone manufacturer for that particular model. Please follow the guidelines provided for the proper usage of the socket:



** Optional and Mandatory Accessory will be charged extra

DO's

1. Ensure that no water enters into the socket by closing the USB flap properly.
2. Use only mobile phone company's authorized USB cable for mobile charging.
3. Do make sure the flap is not damaged while opening / inserting the USB cable.

DON'Ts

1. Do not leave the USB charging flap open / partially closed.
2. Do not attempt to use / charge any other device, other than one mobile phone at a given time.
3. Do not try to force the USB connector in, check if it is inserted in the appropriate direction, to prevent damage.
4. Do not charge your mobile when the engine is in OFF condition.
5. Do not use other device, this port is for charging mobile phones only.



Caution

Secure your mobile phone properly during charging and protect it from any liquid, dust etc.

PRE RIDE INSPECTION

Check the following items before riding

ITEM	WHAT TO CHECK FOR
Engine oil	Availability of oil upto the level (refer page 90)
Transmission oil	Availability of oil upto the level (refer page 91)
Fuel	Enough fuel for the planned distance of running
Tyres	Correct pressure (refer page 98) Adequate tread depth / No cracks or cuts.
Battery	Proper working of electric starter, horn, fuel gauge, pass-by, brake lamp, tail lamp, speedoback illumination, license plate lamp and turn signal lamps.
Lighting	Proper working of head lamp high / low beam and high beam indicator
Steering	Smooth movement / No play or looseness
Throttle	Correct free play of cable / Smooth operation
Brakes	Correct front and rear brake lever play (refer page 92 & 95) Availability of brake fluid upto the level (only in Disc Brake version) (refer page 94)
Wheels	Free rotation
Malfunction indicator	Turned 'OFF' after the engine is started (refer page 28)
ISG malfunction indicator	Turned 'OFF' after the Ignition 'ON' and engine is started (refer page 30)

Caution

Do not switch 'ON' the ignition without minimum level fuel in tank. It will cause damage to the fuel pump.

STARTING THE ENGINE

Ensure availability of fuel in the fuel tank. Insert the control key into the ignition cum steering lock and turn it to the 'ON' position. In side stand retracted condition, apply any one of the brake and press the electric starter switch to start electrically or kick start. Press the start button (one touch noiseless start) without applying the throttle. As soon as the engine starts, release the start button. The engine will not start if the throttle is opened full.

Setting the vehicle in motion

1. Twist the throttle grip slowly towards you and simultaneously release the brake lever gently and smoothly. The vehicle will start moving forward.
2. As the vehicle picks up speed, increase the throttle slowly.

Stopping and parking

1. Close the throttle completely and apply both the brakes simultaneously.
2. Turn the ignition 'OFF'.
3. Park the vehicle on a firm, flat surface.
4. Lock the steering and take out the control key. Finally close the safety key shutter lock.

Warning

Do not raise the throttle rapidly so the vehicle will move forward suddenly and lead to loss of control.

Reduce speed to a safe limit before turning / cornering. Do not apply brake while turning / cornering.

Caution

Do not keep the engine in idling rpm for long and do not open excessive throttle when the vehicle is parked. It leads to overheating of engine and damage to the internal components.

FUEL RECOMMENDATION

Use only BS VI petrol with minimum RON 91. BS VI petrol containing upto 20% of ethanol by volume can be used.

Higher ethanol content in petrol can lead to:

- Degrade plastic and rubber components of fuel system and vehicle parts.
- Cause corrosion damage to metal parts like fuel tank, etc.
- Result in startability & drivability issues.
- Reduced fuel economy.

Ethanol absorbs water very easily, resulting fuel separation. Extra care shall be taken to prevent moisture entry into fuel tank while filling ethanol blended petrol and water washing of vehicle.

Painted parts (viz. panels, covers) shall not come in contact with ethanol blended fuels.

Manufacturer is not responsible for any warranty issues that results from using ethanol blend in excess of 20% by volume in petrol.

In case of any abnormalities observed due to use of ethanol blended fuels, customers are advised to use a different fuel station / brand for standard E20 fuel or contact authorised service centers.



Caution

Never mix oil in petrol in the fuel tank. Always fill fuel from the reputed and reliable fuel stations.

CHECKS AND TIPS FOR IMPROVING FUEL ECONOMY

Regular checks

Carry out the periodic maintenance checks as specified in this manual (refer page 86).

Regular maintenance checks will save fuel and ensure trouble-free, enjoyable and safe riding besides keeping environment clean.

Spark plug

A dirty or defective spark plug leads to wastage of fuel due to incomplete combustion. Clean and adjust the spark plug only if necessary. Replace the spark plug every 12000 kms (1 year). Always use recommended spark plug only.

Air cleaner element

A dirty air cleaner element restricts airflow and increases fuel consumption. Replace the element every 12000 kms.

Since paper filter is used in your scooter it is not recommended to clean the filter. Replace the filter incase of any abnormalities.

Engine oil and Transmission oil

Dirty or less engine oil increases friction between various parts of the engine and reduces the engine life, thereby increases the fuel consumption.

Running with low transmission oil will cause damage to the gears and bearings. **Regularly inspect the engine oil and the transmission oil for correct level and top-up if necessary. Get it replaced at regular intervals as per the maintenance schedule.**

Fuel leak

Inspect and arrest fuel leaks if any from tank and fuel lines. Loss of fuel due to leak may drain the fuel tank completely.

Evaporation

Vehicle parked in the hot sun leads to wastage of fuel through evaporation. Also, lower fuel levels in the tank will have increased evaporation and condensation of moisture inside. Ensure to close fuel tank cap after every filling. If the fuel tank cap kept open for long time, it leads to safety and fuel loss.

Tyres

Low tyre pressure has adverse effect on the vehicle. The **drag on the vehicle** increases resulting in decreased fuel economy. Further more, handling may be adversely affected.

Inspect the tyre pressure regularly (weekly) and inflate it to the recommended pressure (refer page 98). Never use tyres which are worn beyond the permissible limit.

Wheel freeness

Inspect and ensure the wheel freeness by rotating the wheel at least once in a week to avoid wastage of fuel.

Avoid unnecessary idling

While waiting for someone or stopping in signals for long time, if the engine is kept running at idle speed, it causes unnecessary wastage of fuel.

Avoid frequent braking

Anticipate corners and slopes as well as the traffic conditions. **Unnecessary and frequent braking will reduce the fuel economy. Never accelerate and apply brake simultaneously.** It leads clutch shoes wear and wastage of fuel.

Note

The on-road mileage of TVS Jupiter is dependent on several factors like road condition, quality of fuel, riding speed, operation of clutch and brake, tyre inflation, maintenance / timely servicing of vehicle, load etc. and hence will differ from the mileage given under standard test conditions such as made in recognised institutes.

MAINTENANCE SCHEDULE

The maintenance schedule indicates the intervals between periodic services. At the end of each interval, be sure to inspect, check, replace, adjust, lubricate and service as instructed. If the maintenance is not done periodically, it will result in rapid wear and severe damage to the vehicle. If the vehicle is used under high stress conditions such as continuous full throttle operation or if used / operated in dusty climate, certain jobs should be performed more often to ensure reliability of the vehicle. Cylinder head, steering components, suspension and wheel components etc., are key items and require very special and careful servicing. TVS Motor Company Limited strongly recommends that the jobs as per the maintenance schedule be performed by your TVS Motor Company Authorised Main Dealer / Authorised Dealer.

Periodic inspections may reveal one or more parts that may need replacement. Whenever replacing parts on TVS Jupiter, it is recommended that you use only the TVS Motor Company Genuine parts.



Caution

Proper running-in and maintenance are mandatory for making certain that your vehicle is reliable and gives optimum performance at all times. Make sure that the periodic maintenance is performed thoroughly in accordance with the instructions given in this owner's manual.

In more dusty areas, the air filter element required early replacement than the mentioned kilometers to avoid costly damages to the engine.



PERIODIC MAINTENANCE SCHEDULE (months or km whichever occurs earlier)

SERVICE km PERIOD FROM DATE OF SALE	PRE RIDE CHECK	FREE SERVICE			AFTER FREE SERVICE	REMARKS	
		1st 500 ~ 750 30 ~ 60 days	2nd 5500 ~ 6000 6 months	3rd 11500 ~ 12000 12 months	Every 6000 km / 6 months		
ITEMS	ACTIVITY						
Engine oil / Oil filter (strainer)	Replace or Inspect and top-up	-	R / C	R / C	R / C	R / C	Clean strainer
Transmission oil	Replace or Inspect and top-up	-	-	-	-	-	Replace every 24000 km
Spark plug	Inspect and clean or Replace	-	I	-	R	-	Inspect and clean if required. Replace every 12000 km
Air cleaner element	Replace	-	-	-	R	-	Replace every 12000 km
Tappet clearance	Inspect and adjust	-	I	I & A	I & A	I & A	Inspect for any abnormal noise, starting trouble and adjust if required
Drive belt, CVT rollers and clutch shoe	Replace	-	-	-	-	-	Replace every 24000 km
Cover variator	Inspect, clean and lubricate	-	-	I, C & L	I, C & L	I, C & L	
Front and rear suspension	Inspect for proper functioning	-	-	I	I	I	
Evaporative emission Control System	Inspect	-	-	-	-	-	Every 18000 km
Throttle cable / grip	Inspect, clean, lubricate and adjust	-	-	I, C, L & A	I, C, L & A	I, C, L & A	

R - Replace; I - Inspect; T - Top up; C - Clean; A - Adjust; DR - Drain; L - Lubricate; TI - Tighten; S - Set

contd...

SERVICE km PERIOD FROM DATE OF SALE		PRE RIDE CHECK	FREE SERVICE			AFTER FREE SERVICE	REMARKS
			1st 500 ~ 750 30 ~ 60 days	2nd 5500 ~ 6000 6 months	3rd 11500 ~ 12000 12 months	Every 6000 km / 6 months	
ITEMS	ACTIVITY						
Steering smooth operation / play	Inspect and adjust or Lubricate	-	-	-	I & A	-	Inspect and adjust Lubricate if required
All fasteners	Inspect and tighten	-	I	I	I	I	Tighten if required
All bulbs, horn and switches working	Inspect for proper functioning	-	-	I	I	I	
Head lamp beam (focus)	Inspect and adjust	I	-	I	I	I	Adjust if required
Battery Voltage (recharge if required)	Inspect	-	-	I	I	I	Through diagnostic tool or at battery terminal
Brake effectiveness / play	Inspect, adjust & lubricate at cable ends	I	I, L & A	I, L & A	I, L & A	I, L & A	
Brake cam	Clean and lubricate	-	-	C & L	-	-	At 6000 km and every 18000 km thereafter if necessary
Wheels /Tires	Inspect	I	-	I	I	I	Set tyre pressure if required
MIL codes	Inspect	I	-	I	I	I	Connect ride scan tool if MIL glows in speedometer Check and clear DTCs

R - Replace; I - Inspect; T - Top up; C - Clean; A - Adjust; DR - Drain; L - Lubricate; TI - Tighten; S - Set

contd...

RECOMMENDED LUBRICANTS

APPLICATION	QTY	MANUFACTURER	BRAND
Engine oil	700 ml	TVS Motor Company	TVS TRU4 SKUUTA oil (SAE 10W30 API-SL, JASO MB)
Transmission oil	120 ml	-do-	-do-
Front fork oil	92 ± 1 ml / leg	IOC	Gabriel Premium front fork oil
Disc brake fluid*	–	TVS Girling	DOT 3 / DOT 4
Grease	–	Bharat petroleum IOC Bechem Kluber Lubrication	MP Grease No. 3 Servo Gem No. 3 Bechem premium grade 3 Kluber Centplex 2

* Applicable only for Disc Brake version

SELF - MAINTENANCE PROCEDURES

MAINTENANCE FREE (MF) Battery

Battery is located at the front of vehicle inside the front panel. This panel must be removed to access the battery.

1. Follow the procedure for front panel removal:
2. Remove the front panel mounting screws shown in the figure (2 nos.).
3. Gently pull out the front panel by dislocating its lugs by carefully dislocating lugs from its mounting.
4. During reassembly reverse the removal procedure.



Since the maintenance free battery is fitted in your vehicle it is not necessary to top-up with the distilled water. But to ensure the battery performance and long life, follow the steps given below:

1. Check the battery voltage as per the schedule. If the voltage is less than 12.4 volts, charge the battery using **recommended MF battery charger** at TVS Motor Company Authorised Main Dealer / Authorised Dealer.



2. Adding any additional electrical accessories other than TVS Motor Company Limited recommended ones, may lead to disqualification of warranty coverage.

3. While connecting the terminals, observe the correct polarity. Connect the red wire to the '+' terminal and black wire to the '-' terminal of the battery.
4. Petroleum jelly must be applied at terminals to prevent it from corrosion.
5. In case of any abnormality or for removal of battery from the vehicle, contact TVS Motor Company Authorised Main Dealer / Authorised Dealer.



Caution

*Never check the battery charge by shorting the terminals.
Always connect the positive terminal first (red wire) and then negative (black wire) to avoid sparking.
The inversion of the battery wires can damage the battery and the electrical system.*

** To be done by skilled personnel*

Recommendations to maintain battery health during prolonged parking conditions

While your vehicle is parked for prolonged duration, battery continues to discharge and if left unattended can get completely discharged. It is recommended to ride the vehicle for minimum 60 km every week to keep the battery in healthy condition. This could be at a stretch in one ride or several rides during the week. The vehicle speed will vary during the ride but an average speed of minimum 30 kmph will be helpful to ensure proper battery charging. Use kick-starting, if available, to conserve battery charge during such period. This is only a recommendation to maintain battery charge and regular service schedules must be followed to maintain your vehicle in good running condition.

The following is recommendations to users regarding battery maintenance before, during and after long storage of battery:

1. Before Storage

- a. Store the battery only after fully charging it.
- b. Battery fuse to be disconnected and stored safely. This will reduce the sleep mode current and hence enhance storage life of battery.*

- c. Alternatively, battery connecting wires (positive and negative wires) can be disconnected and fasteners can be secured with battery terminals.*

2. During Storage

- a. Store it at room temperature or lower.
- b. Store the vehicle in the shade and protected from rain and cover the vehicle to prevent rodents from entering and damaging the wires.

3. After Storage

- a. Connect the wires and fuse, if disconnected earlier, with ignition switch in 'OFF' position*
- b. Start the vehicle by kick starting (if available).

Warning

Battery develop explosive gases. Keep it away from heat sources. If charging is required the battery must be charged in well ventilated area.

Unusable battery must be disposed in environment friendly manner. Do not discard it with household trash. Handover the battery to the battery dealers or to a recycle center that accept used battery.

(Above recommendations do not consider storage effects on other systems such as induction and fuel systems and wheels)

Periodic Maintenance of Batteries:

- Keep top of battery clean
- Check cables, clamps, and case for obvious damage or loose connections
- Clean terminals and connectors as necessary
- Recharge battery if voltage is below 12.4V.
- Valve Regulate Lead Acid (VRLA) / Lead Acid batteries are prone to water damage. Any water entry, through vents or otherwise; will result in irreparable damage to the battery or the vehicle.

Caution

Never operate the vehicle with discharged battery as it may damage electrical components.

Do not push start the vehicle, use a good battery to start the vehicle.

* To be done by skilled personnel

FUSE

Non-working of electrical systems may be due to safety fuse failure. Short circuit or overload in the electrical system are the main causes for fuse failure. There is a 50A cartridge type fuse is fixed on the right side of the battery as illustrated below:

Similarly, another two more fuse cases containing three blade type fuses (15A x 2 and 10A x 1) located on the left side of the battery as illustrated.

Follow the procedure given below for inspecting and replacing the fuse.

1. Turn 'OFF' the ignition.



2. Remove the front panel as explained in page 84.
3. Take out the fuse case located on both sides of the battery one by one.
4. Open the fuse cases and take out the fuses.

Caution

Do not use the vehicle by **shorting the wires without fuse**. This may result in overheating of electrical items / wiring and may result in fire. Do not use fuse of higher amperage than specified for the safety of electrical system.

Good Fuse

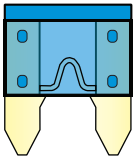

Blown Fuse

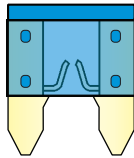

5. Inspect the fuse for failure. If found defective, replace the fuse with a new (one 15A and one 10A additional fuse is provided inside the fuse case itself).
6. Close the fuse case and re-fix it into the battery box.
7. Turn 'ON' the ignition switch and check for proper functioning of electrical systems. In case the fuse fails again, consult the nearest TVS Motor Company Authorised Main Dealer / Authorised Dealer.

SPARK PLUG

To access the spark plug, the cover front has to be removed. Follow the procedure to remove the cover front.

1. Open the seat and remove the top mounting screws (A) from both left and right sides of the cover front.
2. Remove the bottom mounting screws (B) of cover front.
3. Gently pull out the cover front by dislocating its lugs.
4. Clean the dust and mud around the spark plug mounting to avoid falling inside the cylinder.



- Pull out the suppressor cap from spark plug.
Using the spark plug spanner, remove the spark plug.

A spark plug with heavy carbon deposits will not produce strong sparks. Hence, only if necessary, clean the carbon deposits from the spark plug with a small wire brush or spark plug cleaning tool.

Inspect the spark plug electrodes (A) and (B) for any corrosion. If found any, replace the spark plug with a new one. Inspect the spark plug gap visually. If found more, replace the spark plug with a new one.

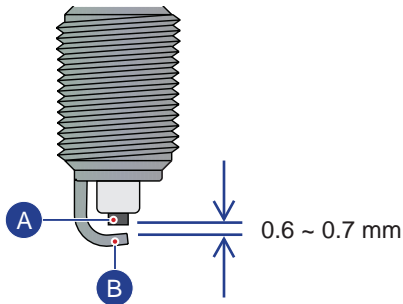

After cleaning and adjusting the gap, reinstall the spark plug and tighten by hand to avoid cross threading. Finally tighten using spark plug spanner.

Caution

*Always use only recommended make and type of spark plug. **Replace spark plug every 12000 km.***

Don't remove the spark plug when the engine is hot. Cover the spark plug hole with cloth when the plug is removed, to prevent dust / water entry.

It is advisable to tighten the new spark plug by hand till the end, using plug spanner tighten by 1/4 turn. Then loosen the plug by 1/8 turn and re-tighten using plug spanner.

ENGINE OIL LEVEL

Check the engine oil level periodically.

1. Place the vehicle on center stand on a flat surface. Wipe-off the surroundings of gauge oil level.
2. Remove the gauge and wipe it clean.
3. Fix the gauge back to its mounting hole. Do not thread in.
4. Take out the gauge and check the oil level. The level should be between minimum and maximum level marks of the gauge (shown in the figure).
5. If the oil is less than the minimum level, add 'TVS TRU4 SKUUTA oil (SAE 10W30 API-SL, JASO MB)' upto the maximum level mark.

6. Wipe out the oil traces with a clean cloth to prevent dust accumulation.
7. Assemble back the gauge oil level.

Caution

If the vehicle is driven with less engine oil, the engine components will be severely damaged.

Check the oil level as per the schedule to avoid costly damage. Do not fill excess oil may cause oil leak. Always use 'TVS TRU4 SKUUTA oil (SAE 10W30 API-SL, JASO MB)' only.

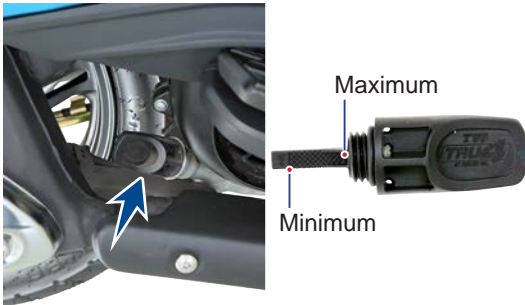

TRANSMISSION OIL - LEVEL

Check the transmission oil level periodically. To check the transmission oil level follow the procedure given below:

1. Place the vehicle on Centre stand on a flat surface.
2. Wipe-off the surroundings of oil level screw.
3. Remove the transmission oil level screw along with a gasket from the rear end of crankcase L.

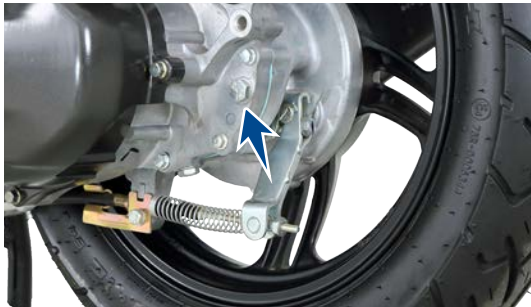

4. Check for the flow of oil from oil level hole. If the level is less (if there is no oil flow), top-up with 'TVS TRU4 SKUUTA oil (SAE 10W30 API-SL, JASO MB)' till the oil just starts to flow out from the oil level hole.
5. Wipe out the oil traces with a clean cloth to prevent dust accumulation.
6. Replace the fiber washer while reassembling the oil level screw.

Caution

If the vehicle is driven with less transmission oil, the transmission components will be severely damaged.

Check the oil level as per the schedule to avoid costly damage. Do not fill excess oil may cause oil leak. Always use 'TVS TRU4 SKUUTA oil (SAE 10W30 API-SL, JASO MB)' only.

BRAKES

Front brake - SBT drum type

1. Measure the free play of the front brake lever at the lever end as shown in the figure.
2. The free play of the brake lever before the engagement of brake should be between 10 ~ 15 mm.
3. If the free play measured is not within the specified limit, turn the adjuster nut (1) fixed at the bottom side slot (marked as 'I') in clockwise direction to reduce the free play or in anti-clockwise direction to increase the free play.

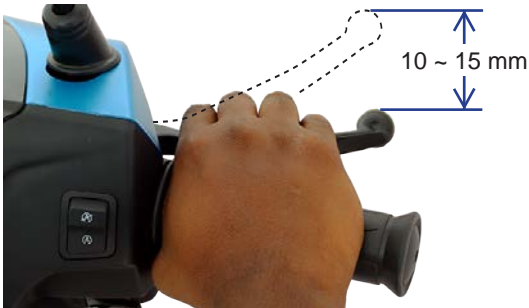

4. After obtaining the necessary free play, inspect for the clearance between the bullet (3) and slot end (4) marked as 'S' as shown in the figure.



- If any clearance is found, turn the adjuster nut (2) at the top side in the slot marked as 'S' in clockwise direction until there is no clearance between the bullet top (3) and the slot top (4).

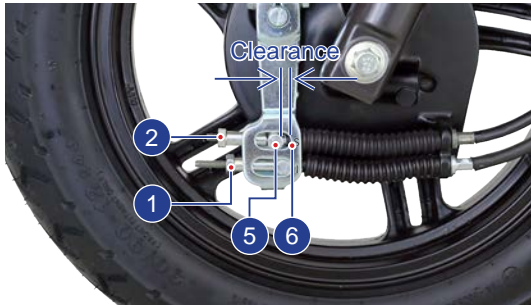

- After adjusting the adjuster nut top, If any clearance is observed in between the bullet bottom (5) and the slot bottom (6) marked as 'I' as shown, then turn the adjuster nut (2) in anti-clockwise until there is no clearance.
- Once again check and confirm the brake play at the lever end.

Warning

Since the vehicle is fitted with Synchronised Braking Technology (SBT) adjust the brakes with additional care. If not it may result in brakes not working properly.

Please contact TVS Motor Company Authorised Main Dealer or Authorised Dealer for further assistance.

Brake shoe wear indicator - Front

When the brake is applied, wear limit index mark (1) on the front brake cam should be within the wear limit indicator (2) on the front brake panel.



Incase the wear limit index mark (1) is going beyond wear limit indicator (2), index the lever to next slot with the help of the Dealer to extend the shoe life.

Caution

Replace the brake shoes as a set, if the wear limit indicator shows beyond the wear limit even after indexing the lever.

Front brake - SBT Disc type

1. You can observe a master cylinder (1) right side of the handle bar under the head lamp housing.



2. A caliper assembly (2) fitted to the fork leg L, a disc (3) on the front wheel and a high pressure hose (4) connecting the master cylinder and the caliper assembly.
3. Check the master cylinder brake fluid level through the view piece glass (A).



Warning

In case of vehicle fitted disc brake SBS version, if there is any abnormality in brake performance, contact TVS Motor Company Authorised Main Dealer / Authorised Dealer.

4. The brake fluid level always should be above the 'MIN' mark provided on the view piece glass of the master cylinder when the cylinder is parallel to ground.
5. If the brake fluid level is below the 'MIN' mark or while applying brake if you feel the brake is more spongy or ineffective due to air entry and if any rattling play is observed in both the brake levers, contact TVS Motor Company Authorised Main Dealer or Authorised Dealer for topping-up the brake fluid, air bleeding and other brake related inspections.

Brake pad wear indicator (Disc brake)

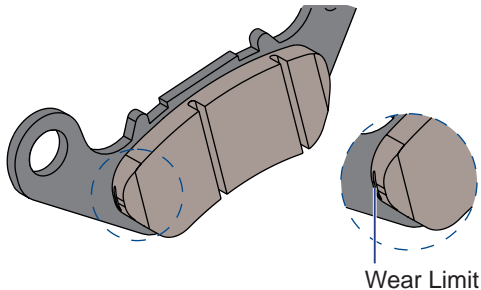

Check for the wear of brake pads visually. If the brake pads wear is found beyond the wear indicator groove as shown in the figure, replace the brake pads as a set with a new one.

Rear brake

1. Measure the free play of the rear brake lever at the lever end as shown in the figure.



Note

Please remember that the rear brake lever free play adjustment to be done only after adjusting the front brake lever play.

Brake shoe wear indicator - Rear

When brake is applied, the wear limit indication pointer (1) on the rear brake cam lever should be within the wear limit indicator (2) on the crankcase LH.

In case the wear limit indication pointer (1) is going beyond wear limit indicator (2), index the lever to next slot with the help of Dealers to extend shoe life.

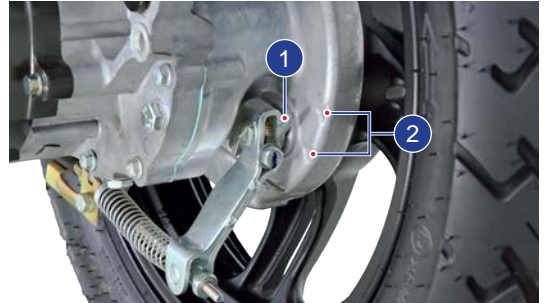

⚠ Caution

Replace the brake shoes as a set, if the wear limit indicator shows beyond the wear limit even after indexing the lever.



2. Free play of brake lever before the engagement of brake should be between 10 ~ 15 mm.
3. If the measured distance is more than the limit, adjust the nut provided at the rear wheel end to obtain the correct play.
4. Turn the adjuster nut in clockwise direction for reducing free play or in anti-clockwise direction for increasing the free play.

⚠ Warning

Check front brake (drum brake type) and rear brake play periodically. However the brake play needs to be adjusted more frequently depending upon the usage.

REAR SHOCK ABSORBERS

TVS Jupiter is provided with 3 step adjustable rear shock absorbers to meet different road and load. There are 3 notches for adjusting spring load. If the spring is adjusted to the minimum notch, then the shock absorber will be softer which is good for light loads. If the spring is adjusted to maximum notch, then it will be stiffer which is good for heavy loads.

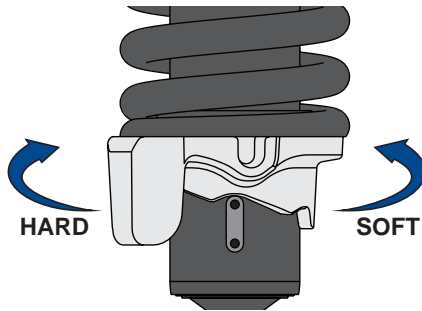

Adjust the spring pre-load by shifting the adjuster to the required notch according to the different load conditions. The more you compress the spring, the suspension becomes more stiff.



TYRES

Tyre pressure

Check the tyre pressure atleast once in a week if not more frequently. Insufficient air pressure in the tyres not only hasten the tyre wear, but also seriously affects the stability of the vehicle.

Under inflated tyres make smooth cornering difficult and over inflated tyres decreases the tyre contact with the ground which can lead to skidding and loss of control.

Be sure that the tyre pressure is within the specified limit at all times.

Tyre pressure in cold condition:

	Solo	Dual
Front	1.70 kg/cm ² (24 PSI)	1.70 kg/cm ² (24 PSI)
Rear	2.25 kg/cm ² (32 PSI)	2.53 kg/cm ² (36 PSI)

Tyre tread condition

Operating the vehicle with excessively worn tyres will decrease riding stability and can lead to loss of control. It is recommended to replace the tyre when the tyre wears off to the tyre wear indicator level (indicated by TWI (A) on the tyre).



Tyre rotation direction

While reassembling the tyres, after removing from the wheel rim, ensure that the arrow mark facing the direction of wheel rotation while fixing the tyre on the wheel rim.

Tyre puncture

Your scooter is fitted with a tubeless tyre on both front and rear wheel. Incase of any puncture / tyre damage, it is advised to visit the nearest tyre manufacturer Dealer or the tyre repair shops who knows the repairing method of tubeless tyre.

It is not necessary to remove the tyre from wheel rim always to attend a puncture.

Even though, if there is need of tyre removal, it is strongly recommended to use a tyre removal / fitment machine.

If at all, tyre levers needs to be used, the levers should be free from sharp edges. Care should be taken not to damage the tyres and rims.

 **Warning**

The tyre inflation pressure in cold condition and the tyre tread condition are extremely important for the performance and safety of the rider. Check the tyres frequently for inflation pressure as well as the wear pattern on it.

Use of a tyre other than the standard may cause instability.

 **Caution**

The side walls of the tubeless tyre which in contact with the wheel rim are only seals the air inside the wheel assembly. Hence care should be taken not to damage the side walls of the tyres during removal / reassembly.

Tyre Maintenance Tips

Inflation Pressure Check - Condition

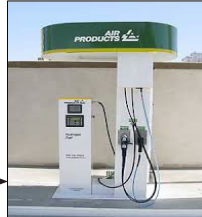

Within
1 km



Within
5 km

Note

If vehicle is in hold condition for long time

- *Need movement of vehicle to avoid particular spot of tyre not to touch the ground for more than week time.*
- *Inflation pressure should check on cold condition maximum travel time should not exceed more than 1 km.*
- *Weekly basis inflation pressure check helps to improve 10% of tread life & fuel efficiency.*

FRONT WHEEL REMOVAL AND REASSEMBLY

Drum brake

1. Remove the axle nut (1) along with a washer.
2. Pull out the axle (2) along with a washer and take out a spacer from the left side of the wheel.
3. Place a support below the foot board to prevent the vehicle from falling and lift the vehicle up.
4. Dislocate the wheel assembly along with brake the panel from front fork. Separate the brake panel from the wheel and take out the wheel.
5. Reverse the procedure for reassembling. While reassembling ensure to locate the lug on fork leg L to the slot in the brake panel.



Disc brake

1. Remove the axle nut (1) along with a washer.
2. Pull out the axle (2) along with a washer and take out a spacer from the right side of the wheel.
3. Place a support below the foot board to prevent the vehicle from falling and lift the vehicle up.
4. Dislocate the wheel disc from caliper assembly and take out the wheel along with hub drive.
5. Reverse the procedure for reassembling. Ensure the proper seating of wheel disc in the caliper assembly and lug on fork leg R to the slot in the hub drive while reassembling.



REAR WHEEL REMOVAL AND REASSEMBLY

1. Place the vehicle on the center stand.
2. Hold the rear brake firmly and remove the wheel mounting nut (A) along with a washer.
3. Slightly tilt the vehicle and take out the wheel from the rear axle.
4. Reassemble the wheel in the reverse order of removal.



Warning

Always make sure, whenever the wheel is removed, the axle nuts are tightened properly to the specified torque.

STORAGE PROCEDURES

1. For storage of TVS Jupiter for longer period of over a month and above, we recommend to carry out the following steps:
2. Clean the vehicle thoroughly. Park the vehicle on center stand.
3. Warm up the engine and drain engine oil and transmission oil. Store the oil, if new, in a dust free container.
4. Empty the fuel tank.
5. Remove the spark plug and feed in several drops of engine oil through spark plug hole. Crank the engine few times and reinstall the spark plug.
6. Remove the battery, store it away from direct sunlight and freezing temperatures.

Caution

Do not park the vehicle on a slope or soft ground or else it may fall down. The exhaust system becomes hot after a run. Park the vehicle in a place where pedestrians or children are not likely to touch the vehicle.

During storage, the battery must be recharged at recommended charger if stored more than a month.

7. Place a suitable support at the bottom of the foot board so that both the tyres are off the ground. This will ensure better tyre life.
8. Cover up the vehicle completely with a clean tarpaulin or any other suitable cover. Store the vehicle inside a garage or similar area to avoid damage due to dust and rain. Make sure that the storage area is well ventilated and free from any source of flame or spark.

TAKING THE VEHICLE OUT OF STORAGE FOR REGULAR USE

1. Take the vehicle out of garage and clean it thoroughly.
2. Remount the battery after bench charging if required.
3. Fill the engine oil (TVS TRU4 SKUUTA - SAE 10W30 API-SL, JASO MB oil) and check the oil level using gauge oil level.
4. Fill the transmission oil (TVSTRU4 SKUUTA - SAE 10W30 API-SL, JASO MB oil) and check the oil level at the oil level screw.
5. Lubricate the parts as instructed in the periodic maintenance schedule.
6. Fill up fresh petrol in the fuel tank.
7. Check and inflate the tyres to the specified tyre pressure.
8. Check and correct the points mentioned in page 76.
9. Turn the ignition switch to 'ON' position. Retract the side stand if the vehicle is parked on side stand. Start the engine and ride out.

 **Caution**

Avoid using alkaline solution like detergent soaps for washing. This may damage head lamp and other lamp assemblies.

RECOMMENDED TIPS WHEN TAKING A LONG TRIP OF MORE THAN 500 KM:

- A) Please keep the following items for use in case of emergency:
1. Tool kit complete.
 2. Recommended spark plug one number.
 3. Throttle, front and rear brake cable each one.
 4. First aid kit.
- B) Precautions to be taken for the journey:
1. Ensure engine oil and transmission oil are up to the level.
 2. Adequate fuel in the fuel tank.
- C) Check your TVS Jupiter for the following:
1. Tightness of all bolts and nuts with correct torque value.
 2. Fitness of tyres / tyre pressure / tread depth.
 3. All bulbs, indicators and horn functioning.

4. Smooth functioning of all cables and their free play.
5. Smoothness of steering operation.
6. Front / rear brake function and rear brake lamp working.
7. Front fork for any abnormality.
8. Spark plug gap and condition of spark plug.
9. Air filter element cleanliness.
10. Correct idling speed.
11. Lubrication of all items mentioned in the periodic maintenance schedule.
12. Any other job as necessary.
13. Have your vehicle checked at any TVS Motor Company Authorised Main Dealer or Authorised Dealer.

 **Caution**

Long journey are to be taken only after the running-in period of 1000 km.

TVS Motor Company Limited ('the Company') give this warranty with respect to the TVS Jupiter manufactured by the Company.

While the Company has taken every care to maintain quality in the manufacture of the TVS Jupiter, the above said warranty is subject to other terms of warranty:

During 5 Years from the date of purchase or during the first 50,000 km of run for the vehicle in the hands of original retail purchaser, whichever is earlier, the parts of the vehicle covered under warranty which prove to the satisfaction of the Company to have a manufacturing defect will be repaired or replaced free of cost.

The Company's obligation under this warranty is limited to repairing or replacing, free of cost, those parts of the vehicle which upon examination by the Company may prove to the Company's satisfaction to have a manufacturing defect, and in such cases the Company's decision either to repair or replace the affected parts will be final. In the event of replacement of parts, the Company also reserves the right to use parts of the same brand as the affected parts or any other brand which is used by the Company in the course of manufacture. All parts replaced under this warranty will become the property of the Company and must be returned to the company.

Limitations of Warranty:

This warranty shall not apply to following condition:

1. Any natural wear and tear, including without limitation, aging.
2. Warranty claims on proprietary items such as tyres, tubes and batteries etc., should be preferred by the user directly on the respective manufacturer, as per their warranty terms and the Company shall not be liable in any manner in respect to the same.
 - Battery warranty for "MF type (Maintenance Free)" is applicable for a period of 21 months from the date of charging or 18 months from the date of sale or 20,000 kms, whichever is earlier.
 - Battery warranty for "Lead Acid type" is applicable for a period of 15 months from date of charging or 12 months from date of sale or 10000 kms whichever is earlier.
3. Parts repaired or replaced under this warranty are warranted only throughout the remainder of the original warranty period.

4. The Company is not liable for any delay in servicing due to reasons beyond the control of the Company or any of its Authorised Main Dealers / Authorised Dealers.
5. In any event, the Company is not liable for indirect, remote, incidental or consequential damages.
6. The Company may make any modification or improvement to vehicles in future production at any time without prior notice and without any obligation to install the same on vehicles previously dispatched for sale.
7. Any claim under this warranty will lie only when the customer:
 - takes his vehicle to an Authorised Main Dealer / Authorised Dealer of the Company and reports the problem he / she felt in the vehicle to enable the Authorised Main Dealer / Authorised Dealer to inspect the same and assess the cause for the reported problems.
 - produces to such Authorised Main Dealer / Authorised Dealer the owner's manual for the concerned vehicle for verification of relevant details.
8. This is the only warranty given by the Company for the TVS SmartXonnect. No employee, Dealer or other person is authorised to extend or enlarge this warranty.

 **Warning**

Modifications to this vehicle not approved by the TVS Motor Company may cause loss of performance and render it unsafe for use and disqualifies for warranty coverage also.

Following Toll Free numbers can be contacted for battery related queries if any.

Incase of EXIDE battery, call :- 1800 103 5454

Incase of AMCO battery, call :- 1800 425 0096

Incase of TATA GREEN battery, call :- 1800 419 8888

Incase of AMARON battery, call :- 1800 425 5858

Following Toll Free numbers can be contacted for Tyre related queries if any.

Incase of TVS Srichakra, call :- 04522443300

Incase of JK tyre, call :- 18002581100

Incase of Maxxis tyre, call :- 1800 532 2888

List of parts not covered under warranty

ITEM	WHAT TO CHECK FOR
Normal Maintenance Operations	Engine tune-up, decarbonizing, fuel system cleaning, oil changes, head light focusing, fastener retightening, ignition timing, clutch and brakes as well as other normal adjustments.
Wear and Tear Items	Chain, sprockets, clutch and brake linings, fasteners, shims, washers, oil seals, gaskets, O' rings and spokes etc.
Electrical	Bulbs, fuse, AHO, Infinity lamps etc.
Service Maintenance Parts	Oil filters, spark plug, air filter, SAI filter, oil and brake fluid
Rubber, Rexine and Plastic Items	All hoses , pipes and plastic aesthetics
Proprietary Items	<p>Battery, tyres and tubes (the warranty terms are subject to our agreement with proprietary OEM)</p> <p>(Battery warranty for "MF type (Maintenance Free)" is applicable for a period of 21 months from the date of charging or 18 months from the date of sale or 20,000 kms, whichever is earlier).</p> <p>(Battery warranty for "Lead Acid type" is applicable for a period of 15 months from date of charging or 12 months from date of sale or 10000 kms whichever is earlier).</p>
Others Factors	<p>Parts of the vehicle getting affected due to atmospheric effect / environmental factors (rusting, paint peel off etc.). However, depending on the vehicle usage condition, warranty would be accepted up to 2 years from the date of purchase.</p> <p>Parts of the vehicle which have been tampered with, altered, repaired or replaced by persons not authorised by the Company and which in the sole judgement of the Company affect the performance of the vehicle.</p>

List of parts not covered under warranty

ITEM	WHAT TO CHECK FOR
Others Factors	Parts which are used in conjunction with parts not made or recommended by the Company.
	Parts suffering damage or resultant damage by accident, misuse, negligent treatment, use of bad quality lubricants or impure fuel or by omission to follow the guidance and instructions contained in this owner's manual.
	Vehicles on which engine number or chassis number is deleted, defaced or altered.
	Vehicles on which any warranty service including scheduled paid service is not availed when it falls due (at TVS Motor Company Authorised Main Dealer / Authorised Dealer).
	<p>Vehicles sold or transferred by original retail purchaser.</p> <p>Vehicles used for racing or any competition or used otherwise than for ordinary personal transportation.</p> <p>Vehicles attached with side cars etc.</p> <p>Vehicles which have been taken out of India.</p> <p>Vehicles affected by natural calamities like flood, earthquake, tsunami, storm etc,.</p>
	If the vehicle has been used for commercial purpose like taxi or used for rental or hiring or any other purpose other than regular personal transportation.

SERVICE INFORMATION

There are seventeen services for TVS Jupiter during warranty period. Of these, first four services are free services for which labour charges are free. In addition to these four free services, we have a scheme of thirteen pay services. For keeping the maintenance track of your vehicle, free and pay service record sheets are attached in the Service Handbook given to you during the time of your vehicle purchase. Please have the relevant record sheet filled by the Dealer who is carrying out the maintenance service.

For availing any of the seventeen warranty services, please take your vehicle and your Service Handbook to any of our Authorised Main Dealers or any of our Authorised Dealer. After effecting the service the Authorised Main Dealer or the Authorised Dealer will affix their stamp on the last column of free or pay service record sheet of Service Handbook for your record and reference. An OTP would be sent to customer's registered mobile number. The same to be shared with the servicing Dealer on or before vehicle delivery.

Periodic maintenance always helps good performance of an automobile and our services are planned to keep your TVS Jupiter performing good. **Please note that carrying out the service for your vehicle at scheduled intervals at any of the TVS Motor Company Authorised Main Dealer / Authorised Dealer is necessary for availing of warranty.** And please also remember that, after the services are over, periodic servicing of your vehicle at appropriate intervals, depending upon its extent of use, will keep your vehicle at its best level of performance.

In case you need any clarification or assistance, please feel free to write to us mentioning the frame number, engine number and date of purchase of your vehicle also the name and place of the Authorised Main Dealer / Authorised Dealer from whom you bought the vehicle and getting it serviced.

Service Department

TVS MOTOR COMPANY LIMITED

P.O. Box No. 4, Harita, Hosur - 635 109,

TAMILNADU, INDIA.

Toll free no:- 1800-258-7111

Planned Service Schedule (kms or month whichever of the two occurs early)*

Sl.No.	Service	Type	Kms	Months
1	1st Service	Free	500 ~ 750	30 ~ 60 days
2	2nd Service	Free	5500 ~ 6000	6
3	3rd Service	Free	11500 ~ 12000	12
4	4th Service	Pay	17500 ~ 18000	18
5	5th Service	Pay	23500 ~ 24000	24
6	6th Service	Pay	29500 ~ 30000	30
7	7th Service	Pay	35500 ~ 36000	36
8	8th Service	Pay	41500 ~ 42000	42
9	9th Service	Pay	47500 ~ 48000	48

Note

Free service enables the customer to avail the service at free of labour charges. Charges for the pay service should be borne by the customer. Cost of engine oil, periodic maintenance parts, filter, brake fluids, all types of greases, petroleum jelly, distilled water, chain cleaner, lubricants, coolants, cleaning cloths for both free and paid services are chargeable to the customer.

** Please remember that, after the above schedule, periodic servicing of your vehicle at appropriate intervals, depending upon its extent of use, will keep your vehicle at its best level of performance.*

DESCRIPTION	TVS Jupiter	
	Front & Rear Alloy Wheel (Front Disc Brake Type)	Front & Rear Alloy Wheel (Front Drum Brake Type)
MANUFACTURER	TVS Motor Company Limited P. B. No. 4, Harita, Hosur - 635 109, India TVS Motor Company Limited Village Bhatian, Bharatgarh Road, Teh Nalagarh, Dist. Solan. Himachal Pradesh - 174 101, India	
ENGINE		
Type	Single cylinder, 4 stroke, fuel injection, air cooled, spark ignition engine	
Cylinder bore	51 mm	
Stroke	55.5 mm	
Piston displacement	113.3 cc	
Compression ratio	10.5 : 1	
Air filter	Dry paper filter element	
Oil filter	Wire mesh	
Lubrication system	Forced wet sump	
Maximum power in kW	5.9 kW @ 6500 rpm	
Maximum torque in Nm	9.2 Nm @ 5000 rpm (without Assist) 9.8 Nm @ 5000 rpm (with Assist)	

DESCRIPTION	TVS Jupiter	
	Front & Rear Alloy Wheel (Front Disc Brake Type)	Front & Rear Alloy Wheel (Front Drum Brake Type)
ENGINE		
Maximum speed	82 km/h	
Engine idling rpm	1450 ± 200 rpm (under warm condition)	
Starting system	Electric starter / kickstarter***	
Emission norms	BS VI	
TRANSMISSION		
Clutch	Dry - Centrifugal clutch	
Primary transmission	CVT (Continuously Variable Transmission)	
Primary reduction	2.65 to 0.8	
Secondary reduction	9.08	
CHASSIS		
Overall length	1848 mm	
Overall width	665 mm	
Overall height	1158 mm	
Seat length	756 mm (usable)	

*** Kickstarter is accessory in Disc SXC variant

DESCRIPTION	TVS Jupiter	
	Front & Rear Alloy Wheel (Front Disc Brake Type)	Front & Rear Alloy Wheel (Front Drum Brake Type)
CHASSIS		
Ground clearance (unladen)	163 mm	
Wheel base	1275 mm	
Kerb weight (with toolkit and 90% of fuel)	105 kg	
Pay load	150 kg	
Maximum laden weight	255 kg	
Steering angle	90°	
Caster angle	25°	
Frame	High rigidity underbone type	
Front suspension	Telescopic hydraulic	
Rear suspension	Gas filled emulsion damper	
Trail length	90 mm	
Front (hand operated)	220 mm dia Disc	130 mm dia Drum
Rear (hand operated)	130 mm dia Drum	

DESCRIPTION	TVS Jupiter	
	Front & Rear Alloy Wheel (Front Disc Brake Type)	Front & Rear Alloy Wheel (Front Drum Brake Type)
TYRE		
Front tyre	90/90 - 12 54J (tubeless)	
Rear tyre	90/90 - 12 54J (tubeless)	
Front tyre pressure*	1.70 kg/cm ² (24 PSI)	
Rear tyre pressure - Solo*	2.25 kg/cm ² (32 PSI)	
Rear tyre pressure - Dual*	2.53 kg/cm ² (36 PSI)	
ELECTRICAL		
Ignition system	ECU controlled ignition	
Spark plug	BOSCH UR6DE	
Spark plug gap	0.6 ~ 0.7 mm	
Battery type	12V, 5Ah MF battery	
Body earthing	Negative	
Generator	Fly wheel machine 12V, 130W	
Head lamp	9V, 9.5W High beam LED / 6V, 5W Low beam LED	
Tail lamp / brake lamp	9V, LED	

* In cold condition

DESCRIPTION	TVS Jupiter	
	Front & Rear Alloy Wheel (Front Disc Brake Type)	Front & Rear Alloy Wheel (Front Drum Brake Type)
ELECTRICAL		
Turn signal lamp	9V, LED	
Position lamp	9V, LED	
Number plate lamp	12V, 3W x 1 bulb	
Instrument panel	LCD screen & LED indicators	
Turn signal indicator lamp		
Low fuel warning lamp		
ECO and power mode lamps		
Horn type	12V, DC	
Fuse blade type	Mini fuse 12V, 15A x 2, 10A x 1 / 12V, 50A x 1	

 **Note**

Using the bulb other than the specified rating can result in overloading of the electrical system or premature failure of the bulb.

DESCRIPTION	TVS Jupiter	
	Front & Rear Alloy Wheel (Front Disc Brake Type)	Front & Rear Alloy Wheel (Front Drum Brake Type)
CAPACITIES		
Fuel tank capacity**	5.1 l	
Fuel	BS VI petrol with minimum RON 91 (containing upto 20% of ethanol by volume)	
Engine / transmission oil grade	TVS TRU4 SKUUTA oil (SAE 10W30 API-SL, JASO MB)	
Engine oil capacity	700 ml	
Transmission oil capacity	120 ml	
Front fork oil grade	Gabriel Premium front fork oil	
Front fork oil capacity	92 ± 1 ml per leg	
Disc brake fluid*	TVS Girling DOT 3 / DOT 4	–

Note

Specifications are subject to change without notice.

** The fuel tank is not a measuring instrument and the capacity of the fuel tank may vary from the indicated capacity

* Applicable only for Disc Brake version

Dear Customer,

It is mandatory under the Motor Vehicles Act to insure all motor vehicles. No motor vehicle can be used in a public place without a valid policy of insurance issued by an authorised insurer. Driving a motor vehicle without any such insurance is an offense under Motor Vehicles Act.

To assist our Customers on their insurance requirements such as the prompt issue and renewal of policies as well as expeditious settlement of claims if any, our preferred insurers are:





ALWAYS USE TVS-M GENUINE PARTS



TVS MOTOR COMPANY LIMITED

P.B. No.4, Harita, Hosur - 635109, Tamil Nadu, India.

Telephone : +91 (4344) 276780.

Fax : +91 (4344) 276878 / 277311.

www.tvsmotor.com